



# Operational & Maintenance Manual

Products:

Installation Site

Contractor

Architect

Distributor



Dear Customer:

Thank you for choosing [ ^ Á [ { ] æ ^ Á as your custom door installation specialist.

The Operation and Maintenance Manual, which is enclosed, has been supplied by Overhead Door Corporation to meet your needs as our customer. Appropriate information for the products installed has been compiled in this manual for your use. We recommend compliance with all of the safety information provided within the manual.

We strongly recommend implementing a preventative maintenance program. Benefits of properly maintaining your door system include:

- Increased operational efficiency and reliability.
- Extended useful life of your equipment.
- Increased probability of dependable equipment performance.
- Elimination of non-budgeted maintenance cost for door service.

As an Overhead Door distributor, we offer you complete product support for your service and maintenance needs. Do not hesitate to call us for assistance.

We hope that you will also continue to consider [ ^ Á [ { ] æ ^ Á for your future product and installation needs. We are firmly committed to providing the finest in Overhead Door products, accessories, and a level of customer support unmatched in the industry.

Sincerely,



# **Operation & Maintenance Manual**

## **Commercial Operators**

### **Table of Contents**

<b>Section 1</b>	<b>General Information</b>
<b>Section 2</b>	<b>Preventative Maintenance</b>
<b>Section 3</b>	<b>Installation Instructions</b>
<b>Section 4</b>	<b>Warranty</b>



# GENERAL INFORMATION



## OVERHEAD DOOR CORPORATION

Overhead Door Corporation, based in Dallas, Texas, is a leading single-source manufacturer of integrated door and operator systems for commercial and residential applications.

Overhead Door is the door solutions provider that delivers expert service and the highest level of performance and reliability. Our comprehensive product line encompasses a wide variety of commercial door solutions including: commercial operators, commercial sectional and rolling service doors, advanced performance rolling doors, and security grilles.

With our nationwide network of more than 400 authorized distributors, we are a leading provider of overhead and garage door systems, and we continue to lead the way with reliable solutions and unmatched professional installation, service and support that keeps customers coming back. The brand trusted for over 90 years, Overhead Door gives home and business owners confidence and peace of mind.



### To locate a distributor:

From the United States, call 1-800-929-3667 (DOOR)

International: 1-717-248-0131

<http://www.overheaddoor.com/Pages/distributor-locator.aspx>

### Contact Information:

Overhead Door Corporation  
2501 S. State Hwy. 121, Suite 200  
Lewisville, TX 75067

Telephone: 1-800-275-3290

[www.overheaddoor.com](http://www.overheaddoor.com)



# PREVENTATIVE MAINTENANCE



## BENEFITS OF PREVENTATIVE MAINTENANCE PROGRAM

- **Increase operational efficiency, safety and reliability**
- **Extend useful life of your equipment**
- **Reduce probability of equipment malfunctioning**
- **Decrease costly downtime**
- **Decrease long-term repair expense**
- **Priority scheduling for service**
- **Establish relationship with experienced, service-oriented professionals**



## SCOPE OF WORK FOR ELECTRIC OPERATORS

For the period \_\_\_\_\_, 20\_\_, through \_\_\_\_\_, 20\_\_, the following services and inspections will be provided as part of the Preventative Maintenance Program for operator(s):

### **ELECTRIC OPERATORS:**

- 1) Inspect and adjust limit switches.
- 2) Inspect and adjust belts.
- 3) Inspect and adjust brake.
- 4) Inspect gear reducer.
- 5) Inspect operator mounting.
- 6) Inspect and test disconnect.
- 7) Inspect and lubricate roller chain.
- 8) Inspect and tighten all sprockets.
- 9) Inspect safety labels, placement and condition.



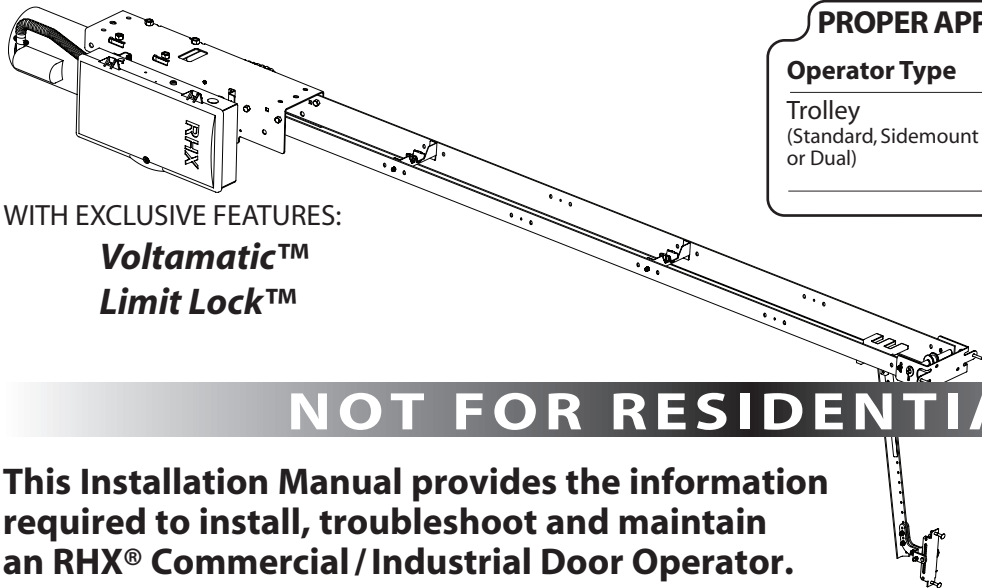


# INSTALLATION INSTRUCTIONS

**RHX**<sup>®</sup>  
HEAVY DUTY COMMERCIAL OPERATOR

The Genuine. The Original.  
**OVERHEAD DOOR**<sup>®</sup>

# TROLLEY



WITH EXCLUSIVE FEATURES:

**Voltamatic™**

**Limit Lock™**

## PROPER APPLICATION

Operator Type	Door Type	Max Door Weight/HP
Trolley (Standard, Sidemount or Dual)	Sectional (Standard or Low Headroom Track only)	1/2HP = 1310 lbs. 3/4HP = 1450 lbs. 1HP = 1650 lbs.

**NOT FOR RESIDENTIAL USE**

This Installation Manual provides the information required to install, troubleshoot and maintain an RHX<sup>®</sup> Commercial/Industrial Door Operator.



# Table of Contents

<b>Section 1</b>	<b>How to use this manual</b> .....	<b>1.1</b>	<b>Section 7</b>	<b>Special Operational Features</b> .....	<b>7.1-7.2</b>
<b>Section 2</b>	<b>Safety Information &amp; Instructions</b> .....	<b>2.1</b>		Operator Cycle Count .....	7.1
<b>Section 3</b>	<b>Critical Installation Information</b> .....	<b>3.1-3.3</b>		GDO & Display Firmware .....	7.1
<b>Section 4</b>	<b>Installation</b> .....	<b>4.1-4.9</b>	<b>Section 8</b>	<b>Troubleshooting</b> .....	<b>8.1-8.5</b>
	Drawbar Assembly.....	4.1-4.6		Display Operation .....	8.1
	Attach Operator .....	4.7		Error Codes .....	8.1-8.2
	Connection to the Door.....	4.8		Run Codes .....	8.2-8.3
	Clutch Adjustment .....	4.9		Troubleshooting Example using Codes.....	8.3
<b>Section 5</b>	<b>Wiring</b> .....	<b>5.1-5.8</b>		LED Indicators.....	8.4
	Line Voltage Wiring .....	5.1		Safe-T-Beam® Troubleshooting Chart .....	8.5
	Low Voltage Control Wiring .....	5.2	<b>Section 9</b>	<b>Service &amp; Maintenance</b> .....	<b>9.1</b>
	External Wire Diagram.....	5.3		Preventive Maintenance Schedule.....	9.1
	Wall Control.....	5.4	<b>Section 10</b>	<b>Appendixes</b> .....	<b>10.1-10.11</b>
	Interlock Switches .....	5.5		Appendix A .....	10.1-10.9
	Monitored Photocell Wiring .....	5.6		Operator Parts Breakdown .....	10.1
	Sensing Edge Wiring .....	5.7		Motor Options.....	10.2
	External Radio Installation .....	5.8		Output Shaft Parts Breakdown .....	10.3
	Connecting Motor/Safety Instructions.....	5.9		Rail Parts Breakdown .....	10.4
<b>Section 6</b>	<b>Operator Setup Procedures</b> .....	<b>6.1-6.9</b>		Carriage/Door Arms Parts Breakdown .....	10.5
	Setting Close Direction .....	6.2		Basic Electric Box Parts Breakdown.....	10.6
	Setting Braking Rate .....	6.3		Electric Box Layout .....	10.7
	Setting Travel Limits .....	6.4		Appendix B .....	10.8
	Alternate Method for Remotely Setting Limits .....	6.5		Screw Terminal Assignments .....	10.8
	Setting Down Limit Overrun.....	6.6		Appendix C .....	10.9-10.11
	Setting Open & Close Modes.....	6.7		Run Codes.....	10.9
	(Optional) Transmitter Programming.....	6.8		Error Codes .....	10.10-10.11
	(Optional) Mid-Stop Limit Setting .....	6.9	<b>Section 11</b>	<b>Warranty</b> .....	<b>11.1</b>
	Monitored Reversing Devices .....	6.10			

# Section 1: How to use this manual

**The 11 sections of this Installation Manual provide the information required to install, troubleshoot and maintain an RHX® commercial/industrial door operator.**

## **Section 2**

Provides important defining information related to safety terminology used throughout this manual, as well as safety related instructions which must be followed at all times while doing any steps/tasks/instructions detailed in this manual.

## **Section 3**

Details pre-installation concerns/issues/decisions that are recommended to be considered and/or resolved prior to beginning any commercial door operator installation.

## **WARNING**

**Failure to correctly perform all steps in sections 4-6 can result in serious injury or death.**

## **Sections 4-6**

Provides step by step installation and set-up instructions for the RHX® commercial door operator. Each section is written such that it must be followed in a step by step order to complete a successful installation.

## **Sections 7-8**

Details important features and troubleshooting information for typical installation and normal operations that may occur.

## **Sections 9-11**

Provides related information on service and maintenance items, operator drawings for use in troubleshooting and service activities, along with important warranty and returned goods policy information.

## Section 2: Safety Information & Instructions

### **⚠️ WARNING**

Overhead Doors are large, heavy objects that move with the help of springs under high tension and electric motors. Since moving objects, springs under tension, and electric motors can cause injuries, your safety and the safety of others depend on you reading the information in this manual. If you have any questions or do not understand the information presented, call your nearest service representative. For the number of your local Overhead Door Dealer, call 800-929-3667, and for Overhead Door Factory Technical Advice, call 800-275-6187.




In this Manual, the words Danger, Warning, and Caution are used to stress important safety information. The word:

- ⚠️ **DANGER** indicates an imminently hazardous situation which, if not avoided, will result in death or serious injury.
- ⚠️ **WARNING** indicates a potentially hazardous situation which, if not avoided, could result in death or serious injury.
- ⚠️ **CAUTION** indicates a potentially hazardous situation which, if not avoided, may result in injury or property damage.

The word NOTE is used to indicate important steps to be followed or important considerations.

### **IMPORTANT** READ PRIOR TO ANY DOOR OPERATION

1. Read manual and warnings carefully.
2. Keep the door in good working condition. Periodically lubricate all moving parts of door.
3. If door has a sensing edge, check operations monthly. Make any necessary repairs to keep it functional.
4. AT LEAST twice a year, manually operate door by disconnecting it from the operator. The Door should open and close freely. If it does not, the door must be taken out of service and a trained service representative must correct the condition causing the malfunction.
5. The Operator Motor is protected against overheating by an internal thermal protector. If the operator ceases to function because motor protector has tripped, a trained service technician may need to correct the condition which caused the overheating. When motor has cooled, thermal protector will automatically reset and normal operation can be resumed.
6. In case of power failure, the door can be operated manually by pulling the release cable to disconnect the operator drive system.
7. Keep instructions in a prominent location near the pushbutton.

POTENTIAL HAZARD	EFFECT	PREVENTION
 <b>MOVING DOOR</b>	<b>⚠️ WARNING</b> Could result in Serious Injury or Death	<b>Do Not</b> operate unless the doorway is in sight and free of obstructions. Keep people clear of opening while door is moving. <b>Do Not</b> allow children to play with the door operator. <b>Do Not</b> change operator control to momentary contact unless an external reversing means is installed. <b>Do Not</b> operate a door that jams or one that has a broken spring.
 <b>ELECTRICAL SHOCK</b>	<b>⚠️ WARNING</b> Could result in Serious Injury or Death	Turn off electrical power before removing operator cover. When replacing the cover, make sure wires are not pinched or near moving parts. Operator must be electrically grounded.
 <b>HIGH SPRING TENSION</b>	<b>⚠️ WARNING</b> Could result in Serious Injury or Death	<b>Do Not</b> try to remove, repair or adjust springs or anything to which door spring parts are fastened, such as, wood block, steel bracket, cable or any other structure or like item. Repairs and adjustments must be made by a trained service representative using proper tools and instructions.

## Section 3: Critical Installation Information

### Job Site Issues to Consider/Concerns

**The following list of items should be considered prior to selecting an operator for a given job site.**

1-Available power supply. 2-Type of door. 3-Potential operator mounting obstructions. Items to consider include, but are not limited to: side room, room above door shaft, room below door shaft, available mounting surface integrity, power supply location, and convenient chain hoist and release cable positioning. 4-Size of door for appropriate operator torque and door travel speed selection. 5-Operator mounting environment. Items to consider include operator location, dampness of location, dustiness of the location and corrosiveness of the location. 6-Door activation needs/requirements. Examples include 3 button control stations, 1 button control stations, radio controls, pull cords, loop detectors, photoelectric controls, key switches, etc. See "Entrapment Protection" section below. 7-Interlock switches are required under certain conditions for doors with pass doors and door locks. See Section 5.5 below. 8-Accessory equipment. Examples include reversing edges and/or photocell beams, which are required for doors set to operate as momentary contact, auxiliary control relays, warning lights, etc.

See "Entrapment Protection" section below.

#### **ENTRAPMENT PROTECTION** (See also page 3.2)

The installation of a fail safe external reversing device (such as a monitored reversing edge or photocell system, etc.) is required on all momentary contact electronically operated commercial doors. If such a reversing device is not installed, the operator will revert to a constant contact control switch for operation (Closing only).

The Reversing Devices currently UL Approved are:

- 1) Miller Edge ME series model edge sensors used in combination with Timer-Close Module P/N OPABTCX.S.
- 2) Safe-T-Beams® from both Genie® and Overhead Door®.
- 3) Commercial Photoeye Kit P/N OPAKPE.S.

**⚠ WARNING:** DO NOT apply line voltage until instructed to do so.

#### **⚠ CAUTION:**

Check working condition of door before installing the operator. Door must be free from sticking and binding. If equipped, deactivate any door locking device(s). Door repairs and adjustments, including cables and spring assemblies **MUST** be made by a trained service representative using proper tools and instructions.

# Section 3: Critical Installation Information

## ENTRAPMENT PROTECTION

The RHX® can be used with the following UL Approved entrapment devices in compliance with UL325 requirements active starting August 29, 2010.

UNTIL ONE OF THESE MONITORED EXTERNAL ENTRAPMENT DEVICES IS INSTALLED, THE RHX® WILL NOT ALLOW MOMENTARY CONTACT OPERATION IN THE CLOSE DIRECTION.

APPROVED DEVICES	ALLOWABLE DOOR WIDTH	ALLOWABLE DOOR HEIGHT
Miller Edge ME series model edge sensors used in combination with Timer-Close Module P/N OPABTCX.S.	ANY WIDTH	See Sq-Ft Charts below Max. Door Height = 24ft. Over 24ft. —contact factory
Safe-T-Beams® from both Genie® and Overhead door®	30 FEET	
Commercial Photoeye Kit P/N OPAKPE.S.	30 FEET	

RHX™ Sectional Door Chart (Sq. Ft.)																						
Model	HP	UL/CSA Listed	Door Series -> Mounting Type	Commercial Steel Insulated & Non-Insulated										Thermacore					Aluminum			
				416	418	420	422	424	426	430	432	591	592	593	594	595	598	599	Panaramic	Commercial		
				16GA. Flush Steel	16GA. Flush Steel Insulated	20GA. Ribbed Steel	20GA. Ribbed Steel Insulated	24GA. Ribbed Steel	24GA. Ribbed Steel Insulated	Nominal 24GA. Ribbed Steel	Nominal 24GA. Ribbed Steel Insulated	Ribbed Steel 1 5/8"	Ribbed Steel 2"	Ribbed Steel 1 3/8"	Raised Panel Steel 1 3/8"	20GA. Flush Steel 1 5/8"	Ribbed Steel 1"	Flush Steel 2"				
RDX-M	N/A	CSA	S	500	134	95	202	154	226	154	226	226	226	202	214	225	154	154	202	177	177	
RDX-S	1/2	CSA	S	900	366	294	490	406	536	448	326	326	326	536	490	326	326	419	200	448	326	506
RDX-S-H	1/2	CSA	S	900	448	366	536	448	632	490	326	326	632	584	326	326	501	200	448	326	526	

**Note:** Total door weight, and not the square footage, is the critical factor in selecting the proper operator. Square foot measurements are based on "square doors". (Example = 16' x 16')

**Note:** Doors that require special windloading and wide doors normally require increased strutting (reinforcement). Strutting doors can significantly increase door weight beyond maximum weight shown. Consult factory personnel in these situations.

## Section 3: Critical Installation Information

### **IMPORTANT INSTALLATION INSTRUCTIONS**

#### **WARNING**

To reduce the risk of severe injury or death:

- 1) READ AND FOLLOW ALL INSTALLATION INSTRUCTIONS.
- 2) Install only on a properly operating and balanced door. A door that is operating improperly could cause severe injury. Have qualified service personnel make repairs to cables, spring assemblies and other hardware before installing the operator.
- 3) Remove all pull ropes and remove, or make inoperative, all locks (unless mechanically and/or electronically interlocked to the power unit) that are connected to the door before installing the operator.
- 4) Install the door operator at least 8 feet above the floor if the operator has exposed moving parts.
- 5) Do not connect the door operator to the power source until instructed to do so.
- 6) Locate the control station: (a) within sight of the door, (b) a minimum of 5 feet above the floor so that small children cannot reach it, and (c) away from all moving parts of the door.
- 7) Install the Entrapment Warning Placard next to the control station and in a prominent location.
- 8) For products having a manual release, instruct the end user on the operation of the manual release.



# Section 4: Installation

## Drawbar Assembly

The Model RHX® Trolley Operator consists of the Power Unit (A), Drawbar Track (B), Chain Guides (C), Front Spreader (D), Front Idler Pulley (E), Drive Chain (F), Drive Sprocket (G) and Drawbar Arm (H)\*\*. The Drawbar track length, chain length and quantity of chain guides will vary by door heights. **Fig. 1.**

- 1) Attach Track to Power Unit using four (4) 7/16"-14 x 1" track bolts, 7/16"-14 keps nuts and 7/16" lock washers (provided). **Fig. 2.**

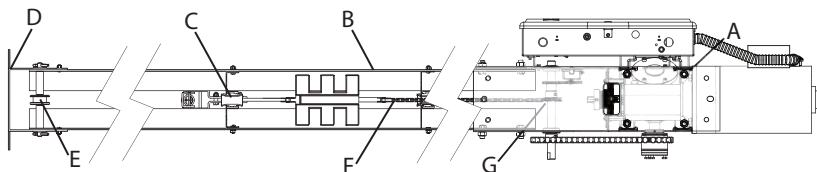
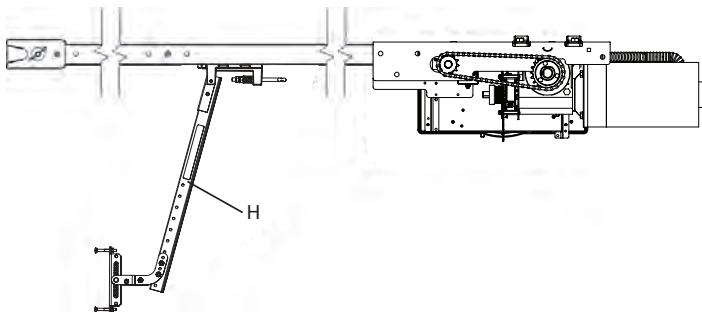


Figure 1



**NOTE:** Drawbar tracks must be (29) inches longer than the door's height. Tracks have been sized properly and pre-punched for the chain guide assemblies from the factory.

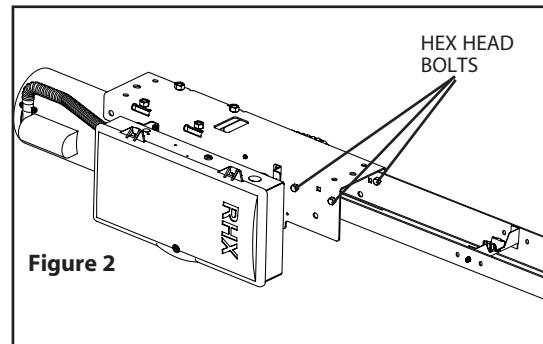


Figure 2

\*\* Trolley Units are also available in Sidemount and Dual Trolley versions.

HP	KIT	PART NO.
1/2, 3/4, 1	Sidemount Trolley Kit	OPAKSMTHX.S
1/2, 3/4, 1	Dual Trolley Kit	OPAKDTHX.S

SIDEMOUNT TROLLEY utilizes a HOIST Operator in combination with a Sidemount Trolley Kit.

## Drawbar Assembly (continued)

- 2) Attach the chain guide assemblies to the drawbar tracks using round head screws and locknuts (provided). **Fig. 3.**

**CAUTION:** Verify that screws are properly seated in track. Failure to seat screws can cause carriage to bind in door track.

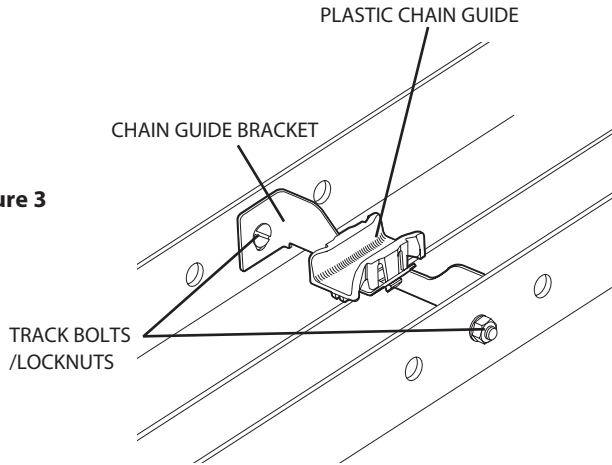


Figure 3

**NOTE:** Space chain guides evenly between operator and header. Add a chain guide for every 4 feet of door height per chart.

UNDER 12'	12' to 16'	16' to 20'	20' to 24'
2	3	4	5

**NOTE:** Chain Guide mounting holes have been pre-drilled at standard locations along the track. If different locations are needed, hole size should be 9/32" dia. Be sure to de-burr the holes.

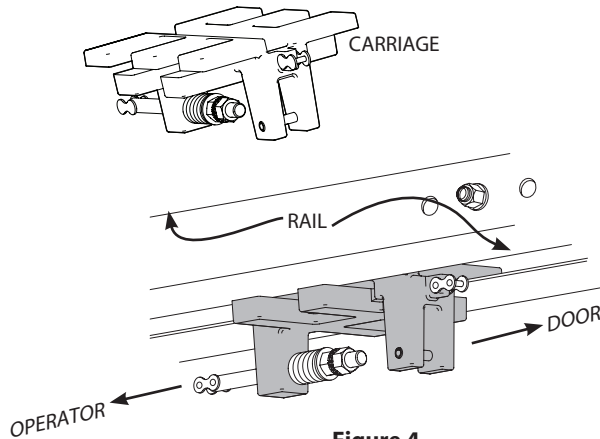
## Drawbar Assembly (continued)

3) Insert the carriage into the tracks as shown in **Fig. 4**.

**NOTE:** The end of the carriage with the chain tension adjustment bolt should be toward the operator.

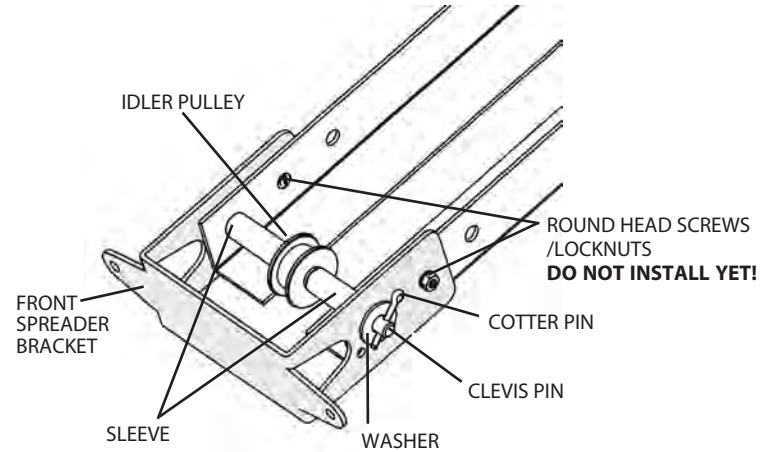
4) Place the spreader bracket in position around the drawbar track. Do not insert the round head screws and lock nuts at this time. The spreader bracket will be held in place (temporarily) by the clevis pin which holds the pulley.

5) Install the idler pulley inside the track by inserting the 3/8" x 4-1/2" clevis pin through one side of the track and as you feed it through an idler sleeve and the idler pulley followed by the second sleeve. Place fender washer (7/16" x 1-1/4") over end of clevis pin. Secure clevis pin using cotter pin. **Fig. 5**.



**Figure 4**

**NOTE:** For building of the spreader bracket assembly on a **Dual Trolley** or **Sidemount Trolley** unit see the separate Drawbar instruction sheet for Sidemount and Dual Trolley models.



**Figure 5**

## Drawbar Assembly (continued)

- 6) Uncoil the drawbar chain and install by routing the chain over the chain guides (A) and around the drive sprocket (B) on the output shaft as shown in **Fig. 6**.
- 7) Attach to Chain Tension Adjusting Bolt (C) using a master link (provided).
- 8) Pass the other end of the chain between the front spreader bracket and the idler pulley (D). Make certain the chain is not twisted.
- 9) Attach the chain to the carriage (E) using a master link.
- 10) Insert the Adjusting Bolt through the hole in the Carriage and place the tensioning spring, flat washer and adjusting nut onto the bolt. **Detail A, Fig 6.**
- 11) Tighten Chain so that it will not jump a sprockets or pulley. Add locknut.

### Check to ensure the following:

- The chain is properly engaging the output sprocket.
- The chain is not twisted.

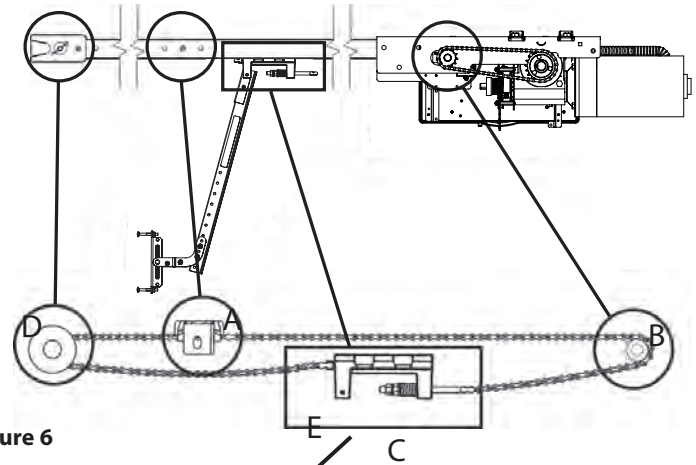
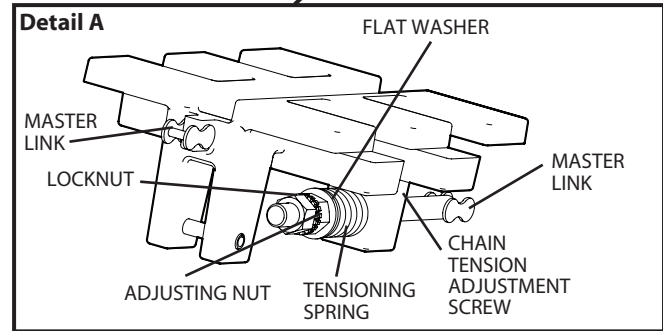


Figure 6



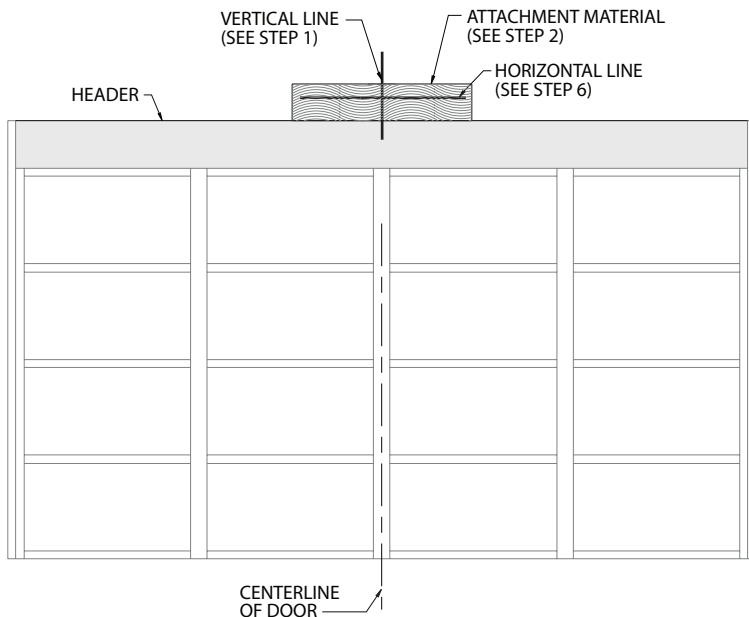
## Drawbar Installation

**⚠ WARNING:** Repairs and adjustments, including particularly to cables and spring assemblies under high tension, must be made by a trained service representative using proper tools and instructions.

**⚠ CAUTION:** Check the working condition of the door before installing the operator. The Door must be free from sticking and binding. If the door is equipped with a latching device, secure the locking bar in the open (unlocked) position.  
If the door lock is to remain functional, an interlock switch **MUST** be installed which will prevent operation of the door whenever the door lock is engaged. Refer to the Wiring Instructions, section 5.5, of this manual for proper connection of the interlock switch.

- 1) Measure the width of the door to determine the center. Make a vertical line above the door, as shown in **Fig. 7**. (If the vertical line is not in line with a door stile, a means of attaching the door bracket to the door must be provided. This can be accomplished by spanning the center of the door's top section (between the top and bottom rail) with a suitable material such as wood or steel).
- 2) Prepare for attaching drawbar to header. If woodwork, or other suitable material is not already in place, securely affix a 2" x 6" block of wood or metal plate as shown in **Fig. 7**.
- 3) Center the block/plate on the header.
- 4) Mark the door's vertical center line on this block/plate.
- 5) Use a level, as shown in **Fig. 8 (pg 4.6)** to find the highest point of travel for the the door.
- 6) Mark a horizontal line across the vertical line you made on the header at 5" above the highest point of door travel.

**NOTE:** On torsion spring doors with an uneven number of panels, the operator may be attached to the stile nearest to the center.



**Figure 7**

## Drawbar Installation (continued)

- 7) Raise the door end (idler pulley) of the drawbar while resting the operator on the floor or other desired material.
- 8) Position the spreader bracket on your centerline with its bottom edge on your horizontal mark. **Fig. 9.**
  - Fasten spreader bracket to header using fasteners appropriate for the header material.

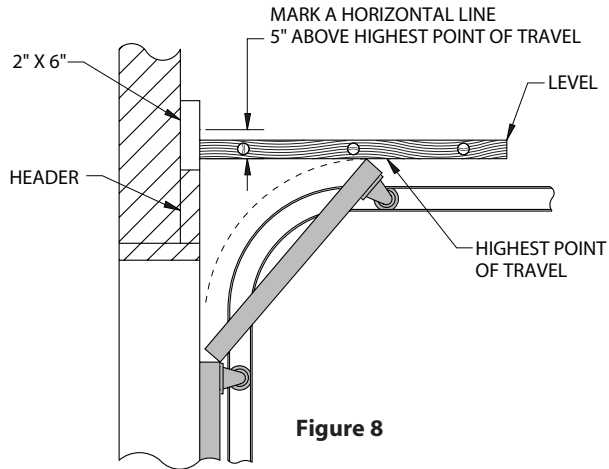


Figure 8

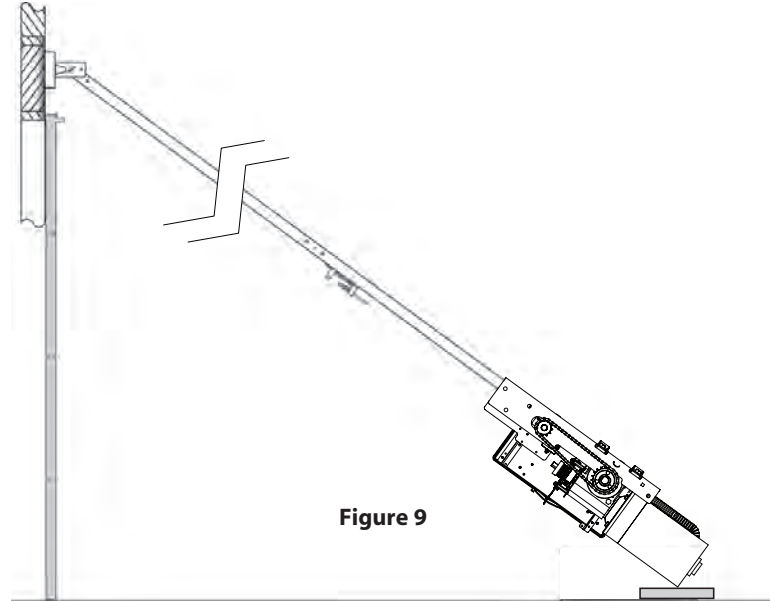
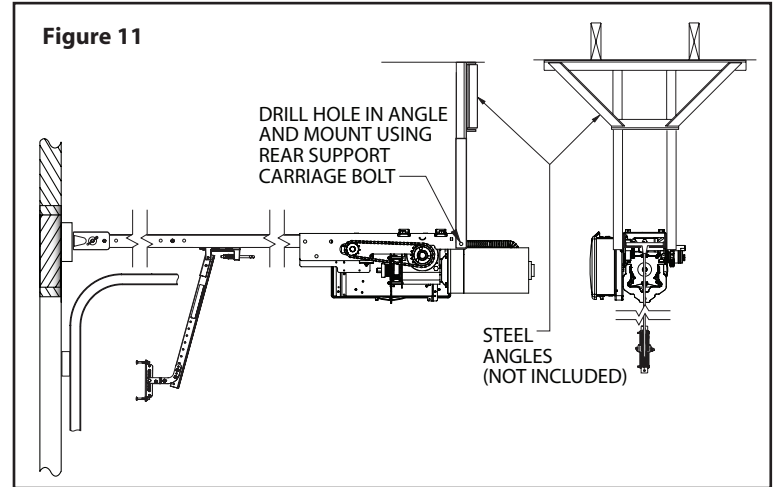
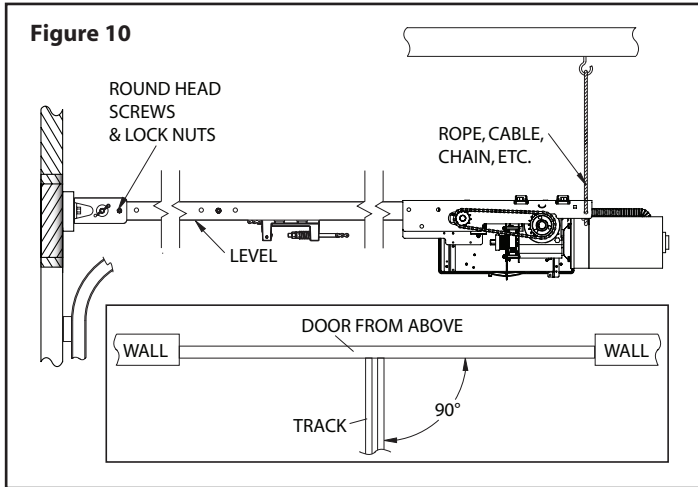


Figure 9

## Attach Operator

- 1) Raise the operator and position it so that the drawbar tracks are level and perpendicular to the face of the door (or the stile where the door bracket will be attached). **Fig. 10.**
- 2) Lock the drawbar tracks into the spreader bracket using the two (2) Round Head Screws (1/4"-20 X 9/16") and two(2) locknuts.
- 3) Secure the operator in position by installing steel angles (not provided) between the ceiling superstructure and the operator power unit. **Fig. 11.**

**NOTE:** Track bolts MUST be installed from inside the track.



## Connection to the Door

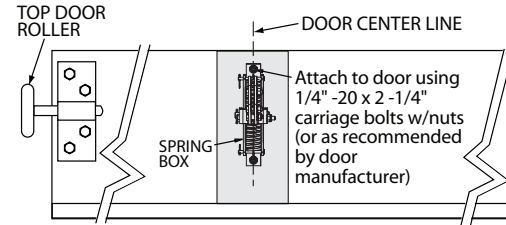
- 1) Pull down on the drawbar arm locking sleeve and attach to carriage.
- 2) Position the spring box on the door as shown in **Fig. 12**, with mounting holes on the door centerline. (Even with or above top door roller).

**NOTE:** Make sure to use reinforcement bracket when attaching spring box to door. Do not attach door bracket directly to door section.

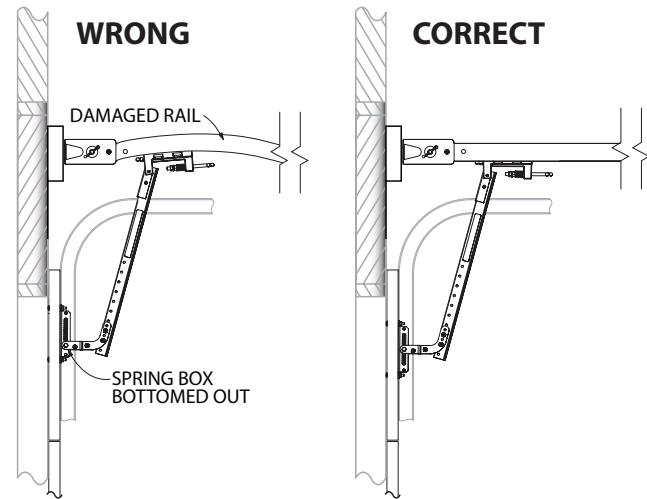
- 3) **For wood doors** fasten the spring box to the door using two 1/4" -20 X 2-1/4" carriage bolts and nuts. **For metal doors** use two 1/4"- 20 self tapping sheet metal screws, or as recommended by the door manufacturer.
- 4) Use two (2) 3/8" -16 X 7/8" bolts and nuts to attach the door arms together.

**NOTE:** If the door strut interferes with the mounting of the spring box, position it below the strut. DO NOT, in any way, cut or modify the strut.

**Make sure that Spring Box does not bottom out when door closes. Fig. 13.**



**Figure 12**



**Figure 13**



## Clutch Adjustment Fig. 14

The RHX® Trolley Operators have a friction style clutch that can be adjusted.

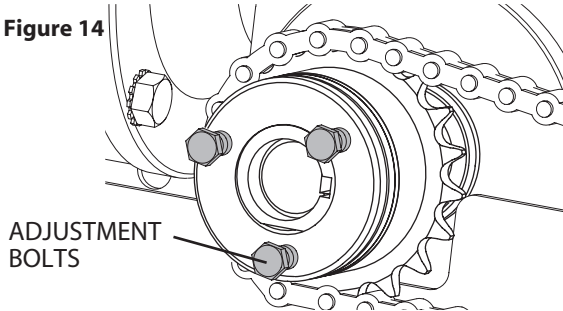
**NOTE:** The clutch is intended to provide protection for the door, the operator and associated equipment. It is not intended for entrapment protection. RHX® Trolley Operators have a motor reversing feature that is integrated with the clutch assembly. If an obstruction is placed in the pathway of the door during operation the RHX® motor will stop and reverse when the clutch begins to slip. Therefore, the adjustment of the clutch should be such that the door and operator function in this manner. The steps for clutch adjustment follow:

### Adjusting the Clutch

The RHX® Clutch does not require any disassembly to adjust.

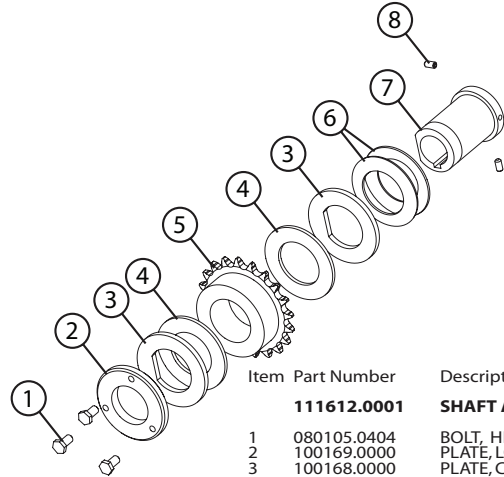
- 1) All adjustments should be made in very small amounts (e.g. turning adjustment bolts 1/4 turn at a time).
- 2) When making adjustments, be sure to turn all 3 adjustment bolts an equal amount. Fig 12.
  - To increase tension, turn adjustment bolts clockwise.
  - To decrease tension, turn adjustment bolts counter-clockwise.
- 3) Clutch needs to be adjusted to a tension just above what is required to open and close door without clutch slippage.

Figure 14



**NOTE:** Periodically check the system for proper clutch action. If clutch starts to slip after working properly for some time, check manual operation of door BEFORE adjusting clutch. The door may not be operating freely or the counterbalance spring may need adjusting. Repairs and adjustments must be performed by a trained service representative using proper tools and instructions.

### Clutch Parts



Item	Part Number	Description	Qty
<b>111612.0001 SHAFT ASSY, HOIST, RHXH</b>			
1	080105.0404	BOLT, HH, PLD, 1/4-20 X 1/2" L	3
2	100169.0000	PLATE, LOCK	1
3	100168.0000	PLATE, CLUTCH THRUST	2
4	100167.0000	LINING, CLUTCH 1.50 X 2.50	2
5	111521.0001	GEAR, #41, 20 TOOTH, 1/2 PITCH	1
6	600170.0000	WASHER, BELVILLE	2
7	100172.0000	SHAFT, CLUTCH 1	1
8	607037.1006	SCREW, SET, 10-32 X 3/8	2

# Section 5: Wiring

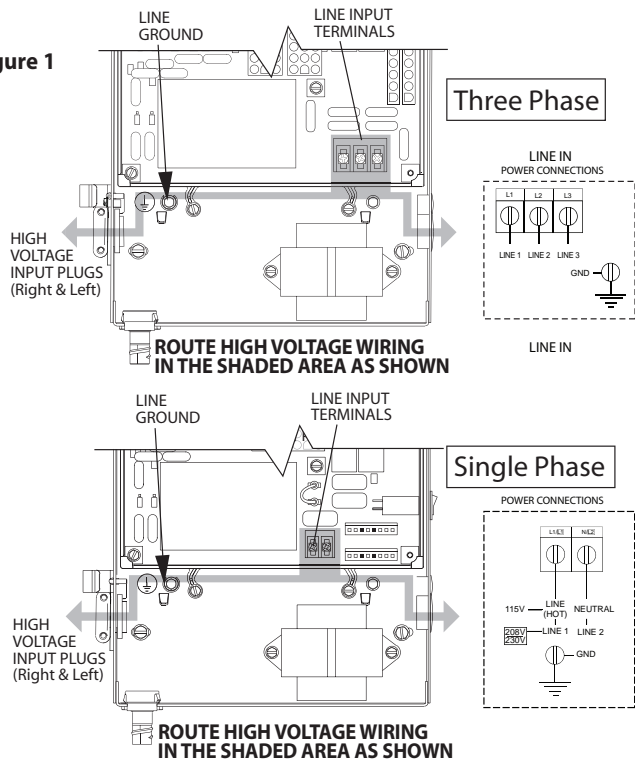
## Line Voltage Wiring Fig. 1

### ⚠ WARNING

- DO NOT apply power to operator until instructed to do so.
- It is strongly recommended, and may be required by law in some areas, that line voltage wiring be performed by a qualified electrician.
- Be sure that electrical power has been disconnected from the input power wires being connected to the operator prior to handling these wires. An appropriate lock-out / tag-out procedure is recommended.
- Line voltage wiring must meet all local building codes.
- Make sure operator voltage, phase and frequency nameplate ratings are identical to the job site line voltage ratings.
- Input power wiring must be properly sized for the operators amperage rating located on the nameplate.
- To reduce the risk of electric shock, make sure the chassis of this unit is properly grounded.

- 1) Remove LINE VOLTAGE INPUT PLUG and install proper fittings and 1/2" conduit.
- 2) Route proper LINE VOLTAGE wires into operator.
- 3) Locate LINE INPUT terminals on circuit board. Using correct connectors, attach wires to LINE INPUTS, and GROUND terminal.
  - Keep low voltage and line voltage wires separate.
  - Route all line voltage wires as shown.
  - Plug all unused conduit holes.

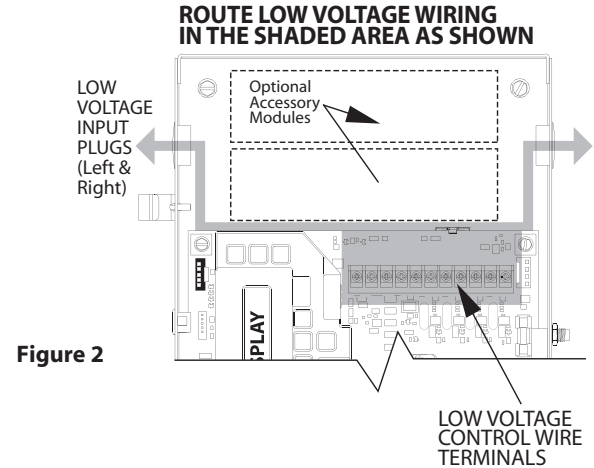
Figure 1



## Low Voltage Control Wiring (general) Fig. 2

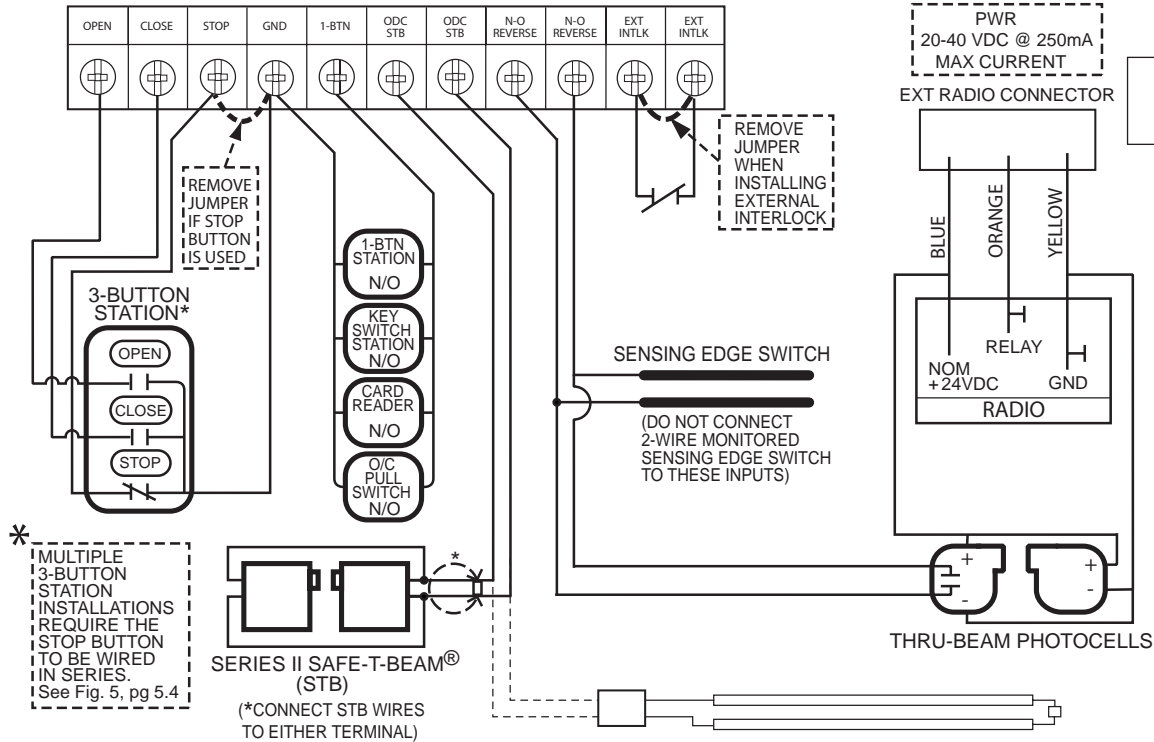
- 1) Connect all LOW VOLTAGE control circuit wires to this side of unit using 1/2" conduit or flexible convoluted tubing.
  - Keep low voltage and line voltage wires separate.
  - Route all low voltage control wiring as shown. This includes all control circuit wires such as wall controls, timers and single button input devices as well as radio control and safety circuit wiring. See Figs 2 through 10 in this section.
  - Plug all unused conduit holes.

**NOTE:** For a detailed description of control wire terminals see Appendix B.



## External Wire Diagram

See Appendix B for detailed description of terminals.



## Wall Control

### ⚠️ WARNING:

- Wall Control(s) must be located so that the door is within sight of the user.
- Attach the Warning placard adjacent to the Wall Control. **Fig. 3A.**

### ⚠️ WARNING:

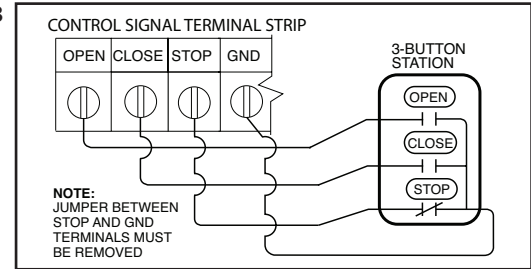
If momentary contact control is to be used, an external reversing device such as a photocell system or sensing edge switch must be used. See pages 5.6-5.7 for installation of entrapment protection devices.

- 1) For a single 3 - button installation, make connections as shown in **Fig. 3.**
- 2) For single button accessory controls, make connections as shown in **Fig. 4.**
- 3) For a multiple 3 - button installations, make connections as shown in **Fig. 5.**

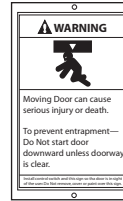
**NOTE:** If an External STOP button is NOT being installed, a jumper wire must be installed between the "STOP" AND "GND" terminals as shown.

**NOTE:** Long Distance Relay Kit wiring is not required for long distance control runs and should not be used.

**Figure 3**

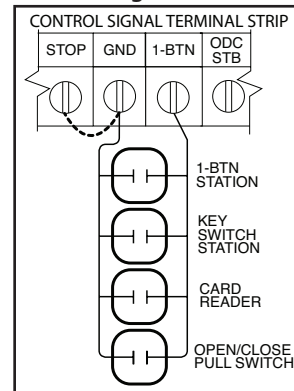


**Figure 3A**

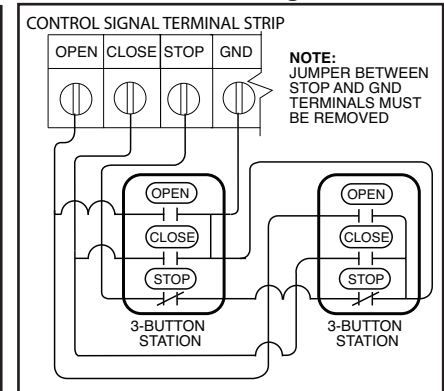


Entrapment  
Warning  
Placard

**Figure 4**



**Figure 5**



## Interlock Switches

- Optional external interlock switches are required with some Sectional or Rolling Steel Doors to prevent the door from operating under certain conditions including the following:
  - If the door is equipped with a functioning door lock, an interlock switch (A) must be installed to prevent electric operation when the lock is engaged.
  - If the door is equipped with a pedestrian pass-through door, an interlock switch (B) must be installed at the pass-through door in order to prevent electrical operation when the pass-through door is open.
- The Switches must be set in the field.

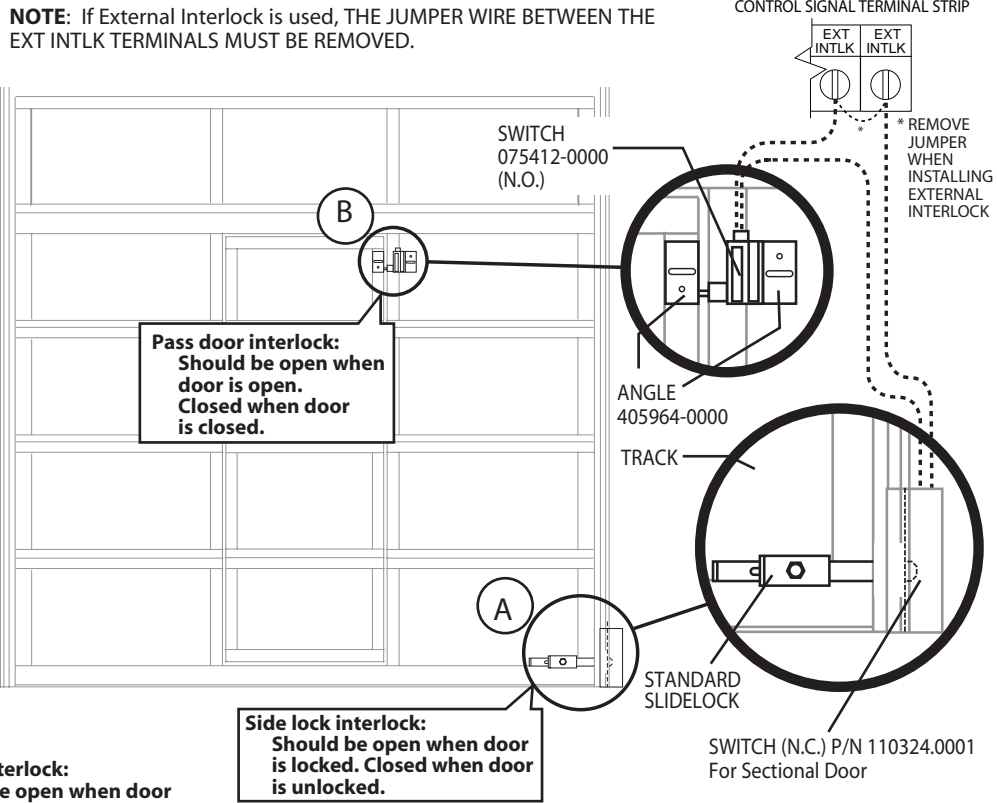


Figure 6

**Side lock interlock:**  
Should be open when door is locked. Closed when door is unlocked.

# Monitored Photocell Wiring

## Series II Safe-T-Beam® Monitored Photocells

- 1) Monitored SERIES II (STB) photocells (P/N OPAKPE.S) can be installed as shown in **Fig. 7**. Wiring to these photocells can be connected to either terminal (they are not polarity sensitive). ( **Troubleshooting in Section 8**).

**NOTE:** Monitored Sensing device must be installed or unit will require Constant Contact to Close.

**⚠WARNING:** Actuating operator using constant contact on the CLOSE button will override external reversing devices, including photocells.

- 2) **To Mount Photocells:** (Kit includes detailed Instructions).
  - Determine location for mounting. They do not need to be directly adjacent to the door but must be somewhere along the wall where there will be an unobstructed line between them. **Fig 8**.
  - Screws provided for mounting on soft material (wood, drywall, etc.)
  - They must extend out away from the wall sufficiently that no door hardware breaks the plane of the photo-beam.

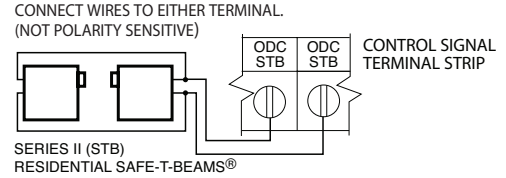
**⚠WARNING:** Photocell systems provide entrapment protection when mounted near the doorway in such a way that the lower portion of an individual's leg will break the photocell beam during normal walking conditions. **Fig. 8**.

## Commercial Non-Monitored Photocells

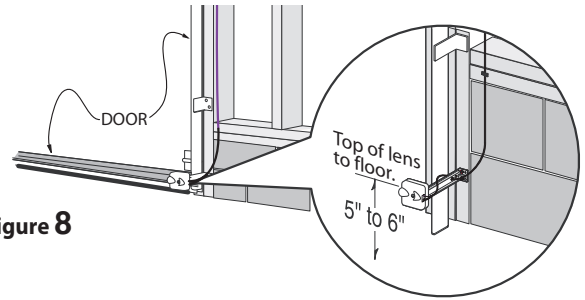
- 1) Nominal 24 Volt DC Commercial photocells with normally open contacts can be connected as shown in **Fig. 9**.

**NOTE:** Blue wire supplies 20 – 40VDC. Photocells used must be compatible with this voltage range.

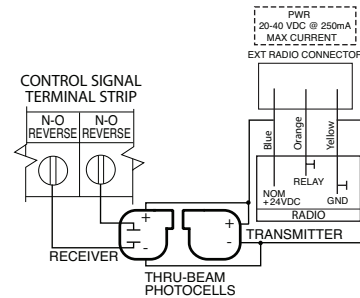
**NOTE:** If no voltage is present at Blue wire, check fuse F-1 on Control board.



**Figure 7**



**Figure 8**

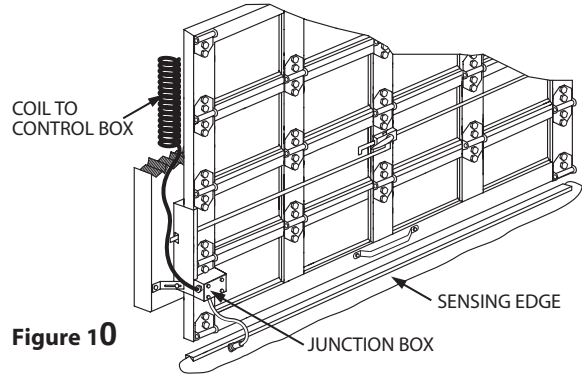


**Figure 9**

## Sensing Edge Switch Installation

**Figure 10** shows an example of a typical sensing edge installation. Left hand side is shown but right hand is a mirror image of this.

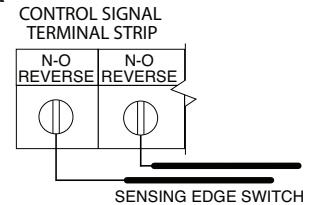
- 1A) If wiring from sensing edge switch to operator is coiled cord or 2 wire jacketed cord:
  - Install junction box 12" above the center of the door opening on same side as sensing switch.
  - Secure one end of cord to junction box using a cable clamp.
- 1B) If connection is to be made through a take up reel cord:
  - Install on same side as sensing edge switch and above door opening and slightly to the side.
  - Install junction box adjacent to take up reel and route the stationary cord from the reel to the box and secure with a cable clamp.
- 2) Secure other end of cord (straight, coiled or reel) to sensing edge switch enclosure using a cable clamp.
- 3) Connect wires of cord to sensing edge switch using wire nuts or other suitable wire connectors.
- 4) Run a straight 2 wire cord from the junction box (Step 1) to the operator electrical box.
  - Secure using cable clamp on each end.
- 5) Join wires in cord from operator to wires in cord from switch using wire nuts or other suitable wire connectors.
- 6A) **Non-monitored** sensing or reversing edge connects to terminal strip using N-O Safety inputs. See **Fig. 11A**.
- 6B) **Monitored** sensing or reversing edge connects Timer-Close Module terminals as shown in **Fig. 11B**.
- 7) Operate the door to make certain cord is free to travel and does not become snared during door opening or closing.
  - Check sensing edge switch for proper operation.



**Figure 10**

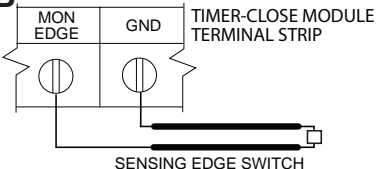
**Figure 11A**

**NOTE:** Do not connect a 2-wire monitored sensing edge switch to these terminals.



**Figure 11B**

**NOTE:** Monitored 2-wire sensing or reversing edge can only be used in combination with a Timer-Close Module.



**⚠ WARNING:** Actuating the operator using constant contact on the CLOSE button will override external reversing devices, including sensing edges or reversing edges.



## External Radio Installation

Although the RHX® Operators are equipped with an internal radio, they also provide a universal connection for an external radio.

### To Add the External Radio

- 1) Plug the pigtail with the 3 wires attached (provided) onto the plug connector marked "EXT RAD." **Fig. 12.**
- 2) Make wiring connections to the wires per the diagram below.

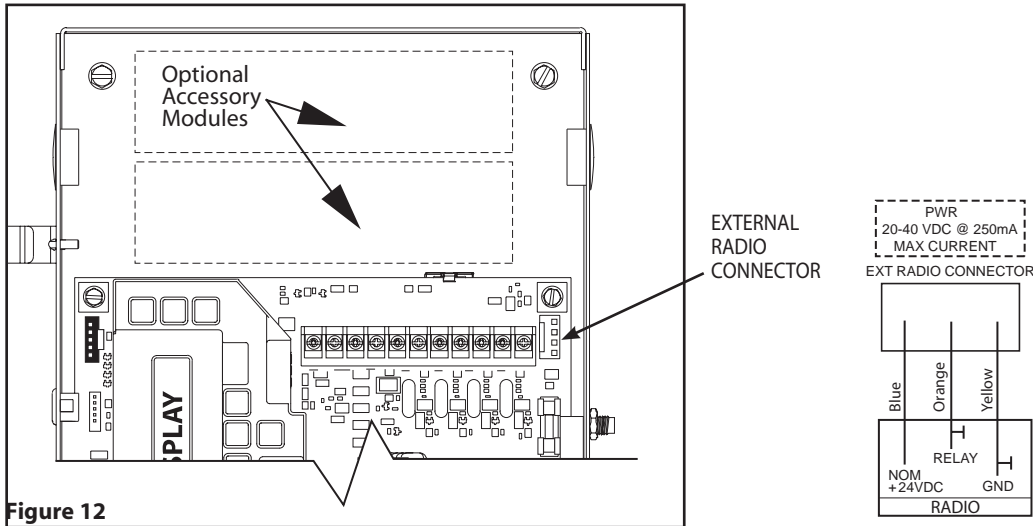


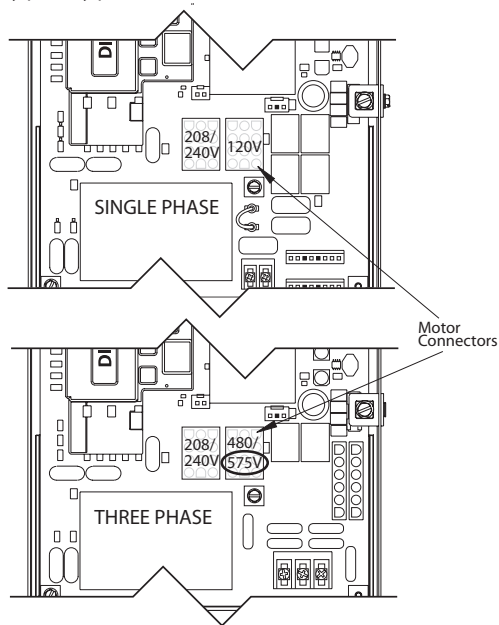
Figure 12

## ⚠ WARNING:

Verify Line Voltage before making any connections to assure that motor harness is connected to proper motor connector on circuit board.

- 1) Plug motor harness into proper motor connector on circuit board in electric box. **Fig. 13.**
- 2) Apply primary power.

Figure 13



## IMPORTANT SAFETY INSTRUCTIONS

### WARNING -

To reduce the risk of severe injury or death:

- 1) READ AND FOLLOW ALL INSTRUCTIONS.
- 2) Never let children operate or play with door controls. Keep the remote control (where provided) away from children.
- 3) Personnel should keep away from a door in motion and keep the moving door in sight until it is completely closed or opened. NO ONE SHOULD CROSS THE PATH OF A MOVING DOOR.
- 4) Test the door's safety features at least once a month. After adjusting either the force or the limit of travel, retest the door operator's safety features.
- 5) For products having a manual release, if possible, use the manual release only when the door is closed. Use caution when operating the release while the door is open. Weak or broken springs may cause the door to fall rapidly, causing severe injury or death.
- 6) KEEP DOOR PROPERLY OPERATING AND BALANCED. See Door Manufacturer's Owner's Manual. An improperly operating or improperly balanced door could cause severe injury or death. Have only trained door systems technicians make repairs to cables, spring assemblies and other hardware.
- 7) SAVE THESE INSTRUCTIONS.

**⚠ DANGER:** After power is supplied to the operator, **Do Not** make contact with components inside the control panel except for the Keypad Keys. **Fig. 1.**

# Section 6: Operator Setup Procedure

## Control Panel

RHX® Operators include a full function control panel including a liquid crystal display (LCD), calibration keys and Open, Close and Stop keys for on board operator control. See **Fig. 1**. The open, close and stop keys function as a 3-button wall control. The Display will show current operator conditions and calibration information. Due to limited character space, some displays will be abbreviated. See Appendix C (pgs. 10.9-10.11) for full display descriptions.

RHX® Operators include a non-volatile memory. The unit will remember all calibration settings plus error code and run code logs, if power is removed from unit.

**⚠ DANGER:** After power is supplied to the operator, **Do Not** make contact with components inside the control panel except for the Keypad Keys. **Fig. 1**.

### TURN ON POWER TO OPERATOR

#### Control Operating Modes

RHX® Operator control boards operate in two modes: Run Mode and Calibration Mode. The control board should normally operate in the Run Mode. The operator is calibrated in Calibration Mode.

#### With the operator standing idle:

PRESS CAL/RUN TO TOGGLE BETWEEN OPERATING MODES.

- The first display in calibration mode is "set close dir."
- The display in run mode will be one of the condition codes listed in Appendix D.

**⚠ WARNING:** DO NOT calibrate operator or operate door unless doorway is in sight and free of obstructions. Door will move during setup. Keep people clear of opening while door is moving.

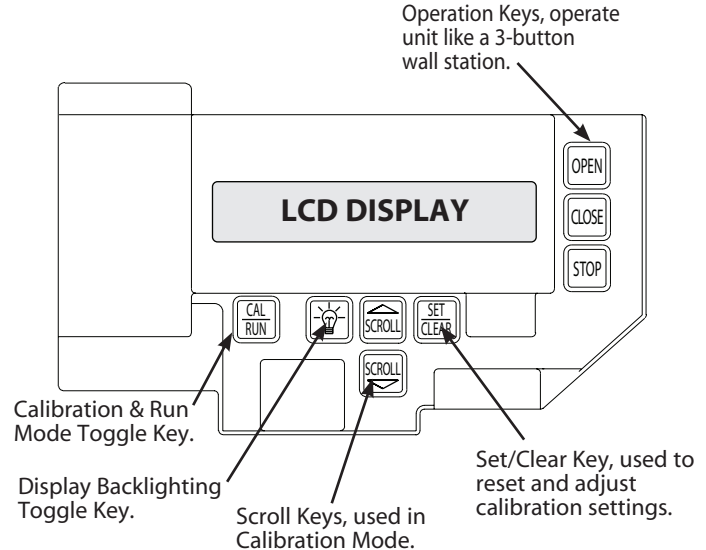


Figure 1

## Setting Close Direction

The direction of motor rotation depends on mounting position and/or how the main input power phases are wired. This setting is used to insure the door is closing and opening according to the input commands.







- 1) If operator is in RUN mode, press CAL/RUN  to enter calibration mode.
- 2) Press SET/CLEAR  to begin the calibration procedure and advance to the next screen. **Figure 3.**
- 3) Briefly press the CLOSE  key. (Pressing the Scroll key at this point will exit this control function.)
  - The display will read “ DID DOOR CLOSE? ” **Figure 4.**
- 4) Press SCROLL  key (up or down) to toggle between YES and NO. **Figure 5.**
  - If YES is selected, no change to operator calibration is made. If NO is selected — the POD will change the operator’s down direction.
- 5) Press the SET/CLEAR  key.
- 6) Press CAL/RUN  to return to run mode.

Figure 2



Figure 3

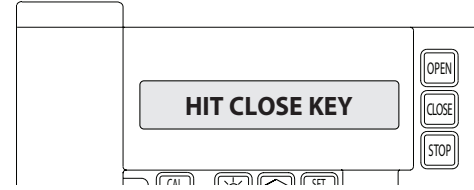
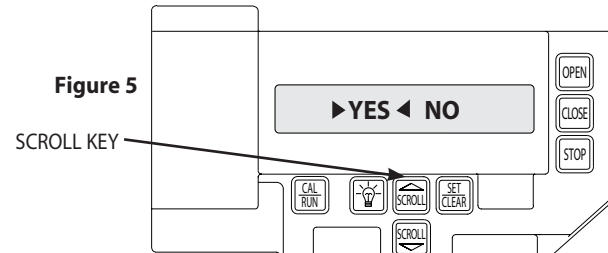






Figure 4

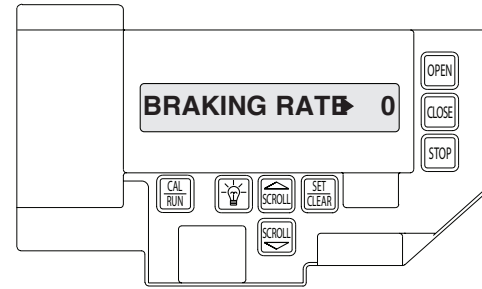


Figure 5



## Setting Braking Rate








- 1) If operator is in RUN mode, press CAL/RUN  to enter calibration mode.
- 2) Press Scroll until display reads "BRAKING RATE >#." where # is the deceleration rate, ranging from 0 to 9. 0 = MAX braking, 9 = MIN braking. **Figure 6.**
- 3) Press SET/CLEAR  key to toggle between 0 and 9—one digit at a time.
- 4) Pick a value and operate the door. Adjust as necessary.
- 5) Press a SCROLL  key to shift to a new function and lock in the setting.
- 6) Press CAL/RUN  to return to run mode.



**Figure 6**








## Setting Travel Limits

### UP and/or DOWN

- 1) If operator is in RUN mode, press CAL/RUN  to enter calibration mode.
- 2) Press SCROLL  until display reads "UP LIMIT>CLR " or "DOWN LIMIT>CLR " **Figure 7.**
- 3) Jog the door using the OPEN  or CLOSE  key until you reach the desired height.
- 4) Press SET/CLEAR  key to switch display to "UP LIMIT>SET " or "DOWN LIMIT>SET ." **Figure 8.**
- 5) Press a SCROLL  key to shift to a new function and lock in the limit setting.
- 6) Press CAL/RUN  to return to run mode.

## Resetting Travel Limits

### UP and/or DOWN

- 1) If operator is in RUN mode, press CAL/RUN  to enter calibration mode.
- 2) Press SCROLL  until display reads "UP LIMIT>SET " or "DOWN LIMIT>SET." **Figure 8.**
- 3) Press SET/CLEAR  to switch display to "UP LIMIT>CLR " or "DOWN LIMIT>CLR"
- 4) Jog the door using the OPEN  or CLOSE  key until you reach the desired height.
- 5) Press SET/CLEAR  to switch display to "UP LIMIT>SET " or "DOWN LIMIT>SET"
- 6) Press CAL/RUN  to return to run mode.

**NOTE:** The recommended setpoint for the DOWN Travel Limit is normally at approximately 2 inches off the floor. This final distance will be covered by the Limit Overrun Function to establish a more accurate seal.

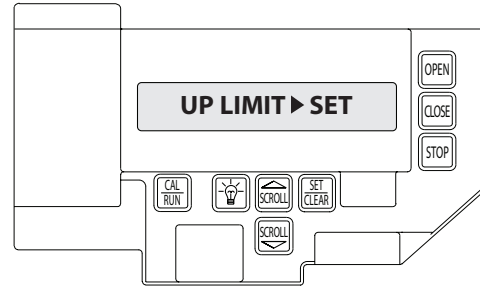


Figure 7

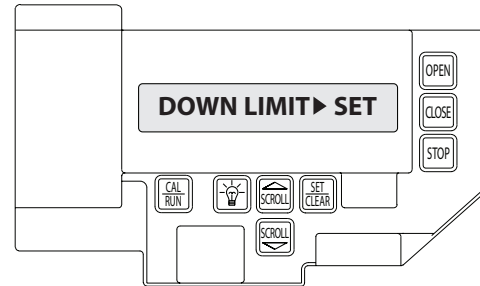


Figure 8

## ALTERNATE METHOD FOR REMOTELY SETTING ALL LIMITS.

*This method will not clear or change an already set limit. To use this method you must first clear the existing limit setpoint.*

- 1) Using the OPEN,CLOSE, STOP buttons on the Wall Station, place the door in the desired position for the limit you wish to set (UP, DOWN or MID-STOP).
- 2) With the door stopped and in desired position:
  - Press and hold the STOP button for, at least 10 seconds. **DO NOT press any other button.**

**NOTE:** Following the setting of a limit you will hear the operator move for a split second as it confirms the setting.






- 3) While still holding the STOP button:
  - To set the **Up Limit**
    - a. Press and hold the OPEN button for one second.
    - b. Release the STOP button, then release the OPEN button.
  - To set the **Down Limit**
    - a. Press and hold the CLOSE button for one second.
    - b. Release the STOP button, then release the CLOSE button.
  - To set the **Mid-Stop Limit**
    - a. Press and hold **both** OPEN and CLOSE buttons for one second.
    - b. Release the STOP button, then release the OPEN and CLOSE buttons.

This procedure will work with the Cal Pod (keypad) in either CAL or RUN mode.

This procedure was specifically designed to prevent the accidental altering of a limit through normal use or a faulty button or wiring.

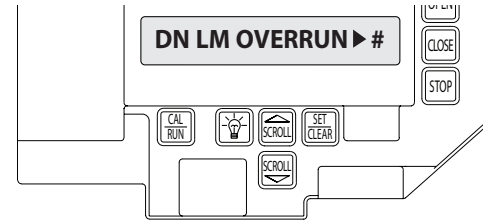
## Setting Down Limit Overrun

**This Setting is a matter of trial and Error**

- 1) If operator is in RUN mode, press CAL/RUN  to enter calibration mode.
- 2) Press SCROLL  until display reads "DN LM OVERRUN>#" where # is the increment of travel beyond the CLOSE Limit ranging from 0 to 9. Zero turns off the Overrun function and the door stops at the DOWN Limit. Nine is the maximum distance the door will travel past the limit. This function is used to insure a good seal at the bottom of the door.  
**Figure 10.**
- 3) Press SET/CLEAR  key to toggle between 0 and 9—one digit at a time.
- 4) Pick a value and operate the door. Adjust as necessary.
- 5) Press a SCROLL  key to shift to a new function and lock in the setting.
- 6) Press CAL/RUN  to return to run mode.

**NOTE:** The actual distance that the Overrun function covers is variable depending on model of operator and size of the door (nominally about 2 inches of travel).

**⚠ WARNING:** The DOWN Limit Overrun function will override external reversing devices, including photo cells and sensing or reversing edges. Therefore, any externally connected devices will be disabled during that portion of door travel which is controlled by the Limit Overrun function.










**Figure 10**










## Setting Open and Close Modes (Constant vs Momentary Contact)

### OPEN

- 1) If operator is in RUN mode, press CAL/RUN  to enter calibration mode.
- 2) Press SCROLL  until display reads "OPEN MODE>MOM" or "OPEN MODE>C-STP." **Figure 10.**
  - MOM=momentary contact, meaning you **press and release** the OPEN  or CLOSE  key and **the door will continue to move** until it reaches its travel limit. (See NOTE)
  - C-STP=constant contact-stop, meaning **if you release the key** prior to the door reaching its travel limit, **the door will stop.**
- 3) Press SET/CLEAR  key to toggle between "OPEN MODE>C-STP" or "OPEN MODE>MOM" on the display.
- 4) Press a SCROLL  key to shift to a new function and lock in the setting.
- 5) Press CAL/RUN  to return to run mode.

### CLOSE

- 1) If operator is in RUN mode, press CAL/RUN  to enter calibration mode.
- 2) Press SCROLL  until display reads "CLOSE MODE>MOM," "CLOSE MODE>C-STP" or "CLOSE MODE>C-REV." **Figure 11.**
  - MOM=momentary contact, meaning you **press and release** the OPEN  or CLOSE  key and **the door will continue to move** until it reaches its travel limit. (See NOTE)
  - C-STP=constant contact-stop, meaning **if you release the key** prior to the door reaching its travel limit, **the door will stop.**
  - C-REV=constant contact-reverse, meaning **if you release the key** prior to the door reaching its travel limit, **the door will reverse direction.** (See NOTE)
- 3) Press SET/CLEAR  key to toggle between "CLOSE MODE>C-STP" or "CLOSE MODE>C-REV" or "CLOSE MODE>MOM" on the display.
- 4) Press a SCROLL  key to shift to a new function and lock in the setting.
- 5) Press CAL/RUN  to return to run mode.

**NOTE:** Momentary contact (**MOM**) or Constant Reverse (**C-REV**) may not be used unless both the OPEN and CLOSE Limits have been set.

In situations where an external reversing device is either not installed or not operating properly, Constant Contact (**C-STP**) **MUST BE USED.**

**⚠ WARNING:** Before momentary contact control can be used, an external reversing device such as a photocell system or sensing edge switch must be used. See pages 5.6-5.7 for installation of entrapment protection devices.

**NOTE:** During adjustment of a Travel Limit, the Open and Close Modes will automatically fail-safe to Constant Contact until the Limit has been set or reset. At that time the Open and Close Modes will revert to their previous setting.

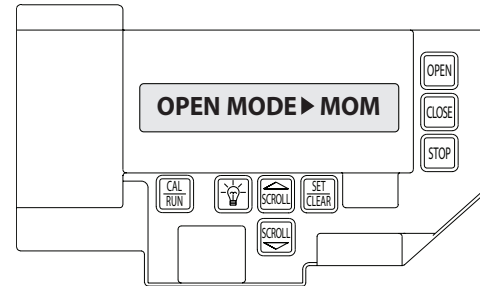







Figure 11

## (Optional) Transmitter Programming

### Adding a Transmitter

- 1) If operator is in RUN mode, press CAL/RUN  to enter calibration mode.
- 2) Press SCROLL  (up or down) until display reads "LEARN NEW XMTR?" **Figure 12.**
  - This question along with the instruction "HIT SET FOR YES" will continuously pan across the display window. (Pressing SCROLL or RUN/CAL will cancel the operation.)
- 3) Press SET/CLEAR .
- 4) Press Transmitter button two times.
  - The display will read "XMTR \_\_\_LEARNED." Where it assigns a random number between 1 and 255 to the transmitter. That transmitter is entered and ready to operate the door. (Label/mark the transmitter.)
- 5) Press SCROLL  (up or down) to move on to another menu item, or CAL/RUN  to exit the CAL mode.

### Removing Individual Transmitter







- 1) If operator is in RUN mode, press CAL/RUN  to enter calibration mode.
- 2) Press SCROLL  (up or down) until display reads "REMOVE XMTR?" **Figure 13.**
  - This question along with the instruction "HIT SET FOR YES" will continuously pan across the display window. (Pressing SCROLL or CAL/RUN will cancel the operation.)
- 3) Press SET/CLEAR .
- 4) Press SET .
- 5) Press SCROLL  (up or down) to move on to another menu item, or CAL/RUN  to exit the CAL mode.



Figure 12









Figure 13



Figure 14




### Removing All Transmitters

- 1) If operator is in RUN mode, press CAL/RUN  to enter calibration mode.
- 2) Press SCROLL  (up or down) until display reads "REMOVE ALL XMTRS?" **Figure 14.**
  - This question along with the instruction "HIT SET FOR YES" will continuously pan across the display window. (Pressing SCROLL or CAL/RUN will cancel the operation.)
- 3) Press the SET  key.
  - The display will read "ARE YOU SURE."
- 4) Press the SET  key.
  - All transmitters are removed.
- 5) Press SCROLL  (up or down) to move on to another menu item, or CAL/RUN  to exit the cal mode.




## Optional Mid-Stop Limit Setting

The RHX® Operator includes a programmable Mid-Stop. This feature allows the operator to stop at a user selectable point when opening. It is used when operating very tall doors that only open to their full height occasionally. The Mid-Stop does not effect the operator when closing. To operate door to full open position from mid-stop, press open button again.





NOTE: Setting of the MID-STOP should only be performed AFTER Travel Limits have been set and door has been cycled fully open and then fully closed.

- 1) Press CAL/RUN  to enter calibration mode.
- 2) Press the CLOSE  to close the door to the down limit.
- 3) Press SCROLL  until display reads "MID-STOP >CLR" Figure 15.

NOTE: If the display reads MID-STOP > SET at this point, first clear the MID-STOP as described below then repeat steps 1-3 and continue.

- 4) Press the OPEN  to open the door to desired mid-stop height.
- 5) Press SET/CLEAR  until the display reads "MID-STOP > SET"
- 6) Press CAL/RUN  to return to run mode.

To CLEAR the Limit

- 1) Press CAL/RUN  to enter calibration mode.
- 3) Press SCROLL  until display reads "MID-STOP >SET"
- 5) Press SET/CLEAR  until the display reads "MID-STOP > CLR"
- 8) Press CAL/RUN  to return to run mode.

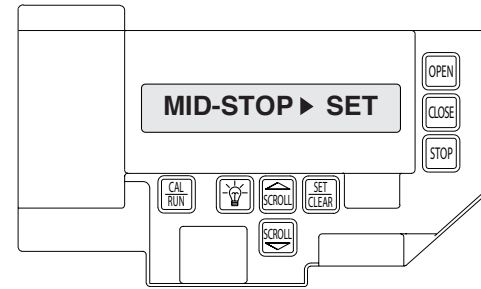







Figure 15

**AN ALTERNATE METHOD FOR SETTING LIMITS  
USING THE WALL BUTTONS IS ON PAGE 6.5**

## Monitored Reversing Devices

### ODC Safe-T-Beams® (OPTIONAL)

- 1) If operator is in RUN mode, press CAL/RUN  to enter calibration mode.
- 2) Press SCROLL  (up or down) until display reads "ODC STB>ON" or "ODC STB>OFF" **Figure 16.**
- 3) Press SET/CLEAR  key to toggle between ON and OFF.
- 4) Press SCROLL  (up or down) to shift to a new function and lock setting.
- 5) Press CAL/RUN  to return to run mode.

**⚠ WARNING:** Photocell systems provide entrapment protection when mounted near the doorway in such a way that the lower portion of an individual's leg will break the photocell beam during normal walking through the doorway. If an alternative mounting location is chosen, it must be approved by the facility owner.

**NOTE:** Installation of Series II Monitored Photocells DOES NOT make the RHX® unit legal for residential use. The Overhead Door Corporation strictly prohibits any installation of an RHX® unit in any residentially zoned construction.

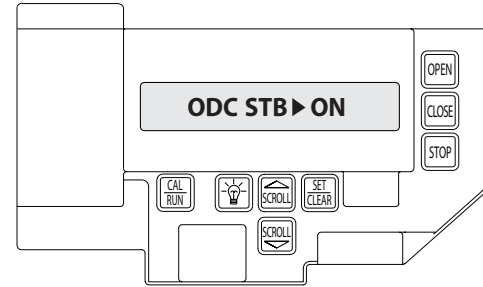





Figure 16

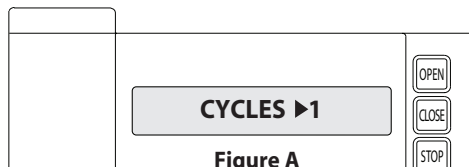
## Current UL Approved Monitored Reversing Devices

- 1) MillerEdge ME series model edge sensors
- 2) Overhead Door Photocells Kit P/N OPAKPE.S  
(Replacement Transmitters-P/N 35046R, Receivers-35047R)
- 3) Retail type Safe-T-Beams® model GSTB-BX P/N 37220R (Genie)  
model OSTB-BX P/N 37221R (OHD)




## Section 7: Special Operator Features (No user input)

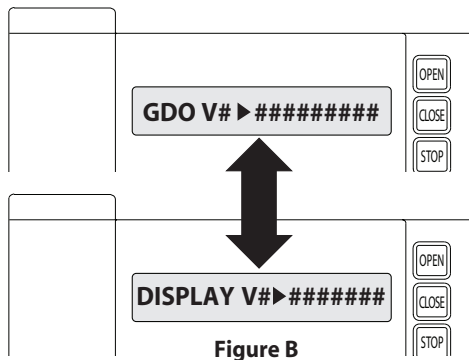
### Operator Cycle Count

- 1) Press CAL/RUN  to enter calibration mode.
- 2) Press SCROLL  until display reads "CYCLES>1,2,3 etc. where the number is the number of open/close cycles the operator has performed. **Figure A.**
- 3) Press CAL/RUN  to return to run mode.



### GDO and Display Firmware





- 1) Press CAL/RUN  to enter calibration mode.
- 2) Press SCROLL  until display reads "GDO V# > #####." **Figure B.** This display will cycle between the version number of the current GDO firmware and the current Display Firmware.
- 3) Press CAL/RUN  to return to run mode.



## Operator Type Fig. 3

RHX® operators are available for use in jackshaft or trolley configurations. The same control board is used for either configuration, however the control board must be set for the appropriate GDO configuration. A board set for trolley mode will not work in a jackshaft operator and vice-versa.

**NOTE:** The GDO type is factory set. The installer should not have to set this feature. However, if the GDO type is inadvertently changed, or if a board needs to be replaced in the field, follow these instructions to set GDO type.

- 1) Press CAL/RUN  to enter calibration mode.
- 2) Press SCROLL  until display reads "GDO TYPE > ."  
This will display the current GDO type.
- 3) Press SET/CLEAR  until display indicates correct GDO type (J-SHAFT or TROLLEY)
- 4) Press CAL/RUN  to return to run mode.

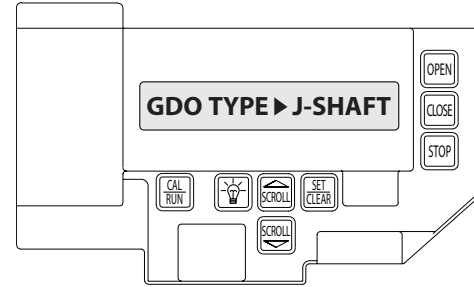


Figure 3

# Section 8: Troubleshooting

## Display Operation in Run Mode

RHX® operators display their status on the integrated display. Each time the operator runs, stops, reverses or refuses to run, the display will indicate why the action did, or did not, take place.

Once an error code has been generated, the RHX® operator will continue to display the error code while the operator is not running. This error code can be cleared by pressing the STOP button or STOP key on the keypad. The error code will automatically clear when the operator stops at the down limit. Error codes will continue to be stored in the RHX® operator's Error Code Memory after they have been cleared from the display in the Run Mode.

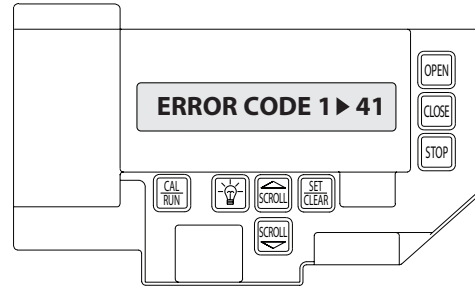


Figure 1

## Error Codes

To aid in troubleshooting problems, RHX® operators include an error code memory that stores the last 10 error events. These codes are stored with or without power. The last error code detected is also displayed on the LCD until the stop button or key is pressed or the operator stops at the down limit.

The error code memory stores the last 10 error codes in sequence. Once 10 codes are stored, the oldest code is erased to make room for the newest code. These codes are displayed in calibration mode. The display will flash the number of the error code and the 2-digit error code followed by a description of the error code. **Fig. 1 & 2.**

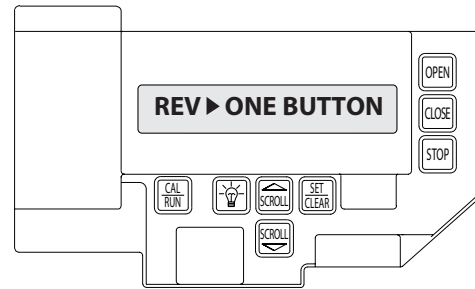






Figure 2

## Error Codes (continued)

### To view the error code memory:

- 1) Press CAL/RUN  to enter calibration mode.
- 2) Press SCROLL  until display reads "ERROR CODE 1 >".
  - The display will begin flashing the error code number and 2-digit error code followed by its description.
  - Reminder: Error code number 1 is the latest code generated.
- 3) Press SET/CLEAR . The display will now read "ERROR CODE 2 > ." (This is the error code which was generated before error code 1.)
- 4) Repeat step 3 until all 10 error codes have been displayed or move on to step 5 when ready.
- 5) Press CAL/RUN  to return to run mode.

**NOTE:** For all error codes see Appendix C, Sections 10.10 - 10.11.

## Run Codes

RHX® operators also include a run code memory that stores the last 10 run events. These codes are stored with or without power. Each time the operator runs or stops, it generates a code that it stores in this memory (Why the operator ran or stopped). Used together with the error code memory, it becomes a powerful troubleshooting aid.

The run code memory stores the last 10 codes in sequence. Once 10 codes are stored, the oldest code is erased to make room for the newest code. These codes are displayed in calibration mode. The display will flash the number of the run code and the 2-digit run code followed by a description of the run code. **Fig. 3 & 4.**

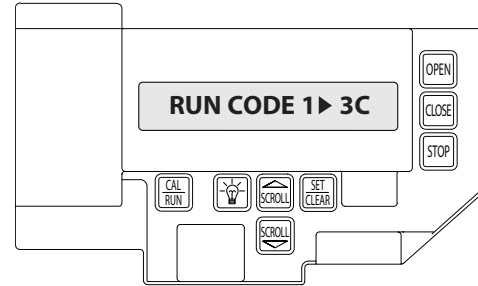


Figure 3

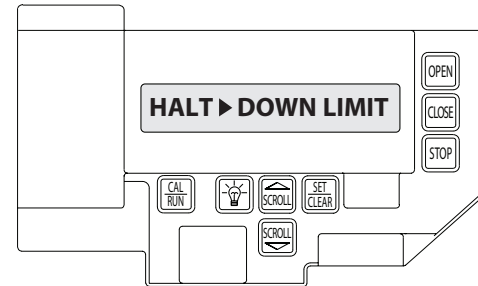






Figure 4



## Run Codes (continued)

### To view the run code memory:

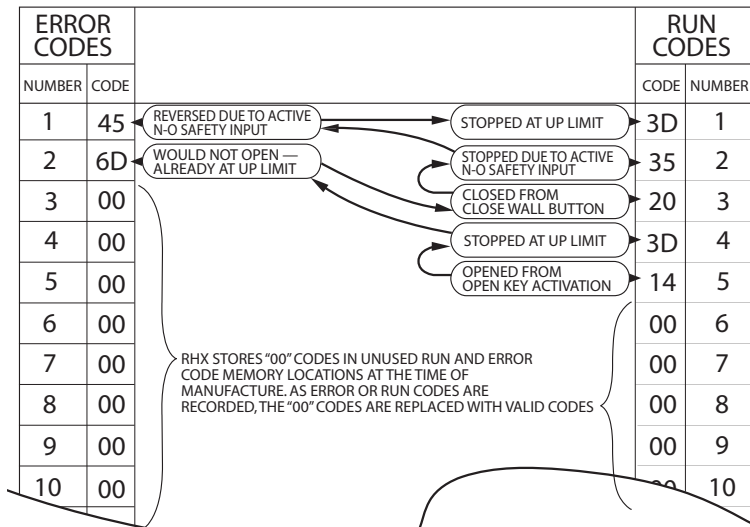
- 1) Press CAL/RUN  to enter calibration mode.
- 2) Press SCROLL  until display reads "RUN CODE 1 > ."
  - The display will begin flashing the run code number and code followed by its description.
  - Remember: run code number 1 is the latest code generated.
- 3) Press SET/CLEAR . The display will now read "RUN CODE 2 > ." (This is the run code which was generated before run code 1.)
- 4) Repeat step 3 until all 10 run codes have been displayed or move on to step 5 when ready.
- 5) Press CAL/RUN  to return to run mode.

**NOTE:** For all run codes see Appendix C, Section 10.10.

### TROUBLESHOOTING EXAMPLE USING RUN AND ERROR CODE MEMORIES. Fig. 5

1. In Calibration Mode, display and write down each Run Code and Error Code stored in memory.
2. List as shown in Fig. 5.
3. Refer to Appendix C to interpret the codes.

In this example, the operator was opened using the OPEN key on the keypad and stopped at the up limit. The OPEN wall button was then activated, causing the "6D" code to be generated since the operator could not open when it is already at the up limit. The CLOSE wall button was then activated, causing the operator to close. While closing, the Normally-Open (N-O) Safety Input was activated, causing the operator to stop and then reverse, stopping at the up limit.

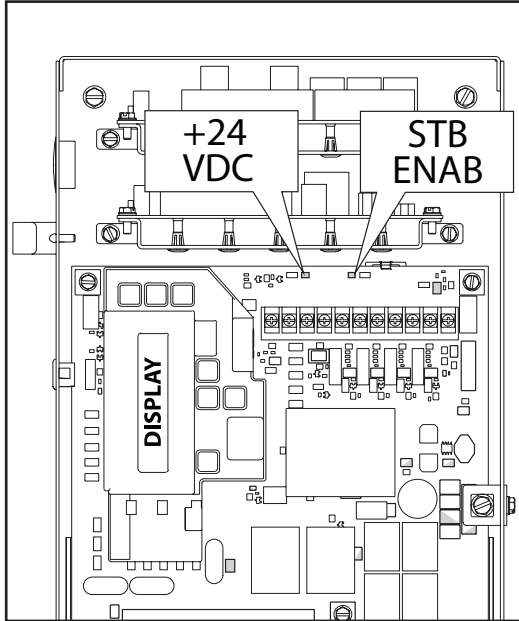


**Figure 5**

## LED Indicators Fig. 6

RHX® operators include a self-diagnostic circuit board using troubleshooting LED indicators to signal the technician of a problem.

Figure 6



### TROUBLESHOOTING LED's

STB ENABLE	NORMALLY ON - STB ENABLED	OFF - STB DISABLED
+ 24 VOLTS DC	NORMALLY ON - POWER AVAILABLE	OFF - CHECK AC POWER SUPPLY CHECK FUSES

## Safe-T-Beam® Monitored Photocell Self-diagnostic Troubleshooting Chart

SOURCE (RED LED)	SENSOR (GREEN LED)	INDICATED CONDITION	REQUIRED ACTION
● ON	● ON	NORMAL OPERATION	NONE REQUIRED
○ OFF	○ OFF	1. POWER HEAD NOT POWERED 2. WIRING FROM POWER HEAD BAD	1. CHECK BREAKERS, FUSES, PLUGS 2. CHECK WIRING FOR OBVIOUS SHORTS
○ OFF	● ON	1. WIRING TO SOURCE MISSING OR BAD 2. POWER HAS BEEN INTERRUPTED	1. CHECK WIRING 2. REMOVE POWER AND REAPPLY
2 BLINKS, PAUSE (REPEAT)	● ON	1. BEAM NOT ALIGNED 2. BEAM OBSTRUCTED 3. SENSOR DEFECTIVE	1. CHECK ALIGNMENT 2. CHECK FOR OBSTRUCTION 3. CALL CUSTOMER SERVICE
2 BLINKS, PAUSE (REPEAT)	○ OFF	1. WIRE TO SENSOR MISSING OR BAD 2. SENSOR DEFECTIVE	1. CHECK WIRING 2. CALL CUSTOMER SERVICE
3 BLINKS, PAUSE (REPEAT)	● ON	1. SENSOR RECEIVING INTERFERENCE	1. ATTEMPT TO DETERMINE SOURCE OF INTERFERENCE 2. CALL CUSTOMER SERVICE
4 BLINKS, PAUSE (REPEAT)	● ON	1. SOURCE NOT SENDING PULSES 2. SOURCE DEFECTIVE	1. CALL CUSTOMER SERVICE 2. CALL CUSTOMER SERVICE

**⚠ WARNING:** ACTUATING THE OPERATOR BY USING CONSTANT CONTACT ON THE CLOSE BUTTON WILL OVERRIDE EXTERNAL REVERSING DEVICES, INCLUDING PHOTOCELLS.

**⚠ WARNING:** OVERHEAD DOOR CORPORATION RECOMMENDS THAT LINE VOLTAGE WIRING BE PERFORMED BY A QUALIFIED ELECTRICIAN. SEE SECTION 5 FOR ADDITIONAL WIRING INSTRUCTIONS.

# Section 9: Service and Maintenance

## Maintenance Schedule

The following table provides a schedule of recommended Service and Maintenance items to be completed by a trained service representative.

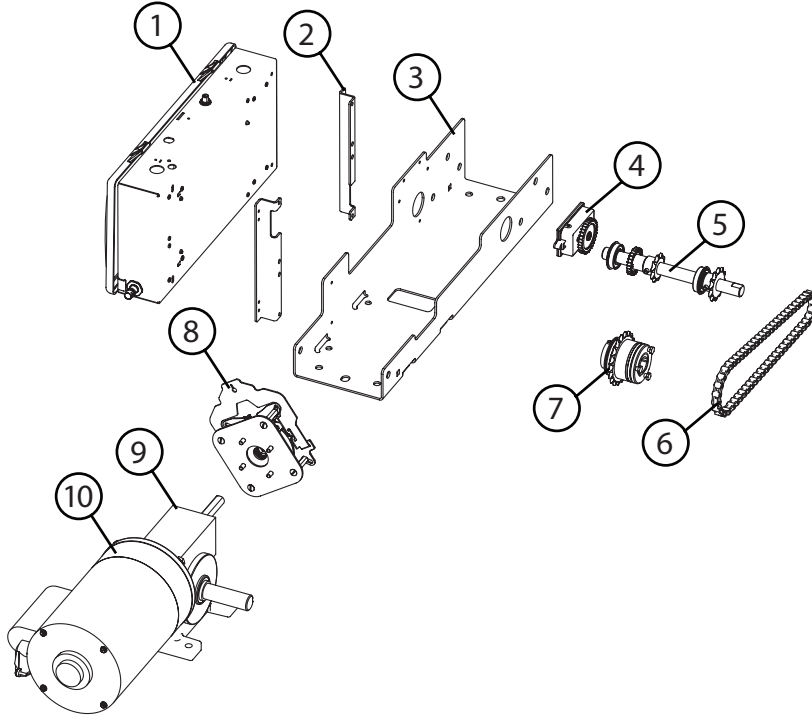
**⚠ CAUTION:** Failure to perform the recommended Service & Maintenance may result in premature failure of the operator.

SERVICE ITEM	SERVICE INTERVAL (FREQUENCY)			
	MONTHLY	EVERY 6 MO. OR 5,000 CYCLES	EVERY 12 MO. OR 10,000 CYCLES	EVERY 36 MO. OR 30,000 CYCLE
MANUAL OPERATION OF DOOR		●		
CHECK DRIVE CHAINS AND LUBRICATE			●	
* PHOTOCCELL/ SENSING EDGE OPERATION	●			
CLUTCH ADJUSTMENT			●	
CHECK FOR LOSE OR MISSING HARDWARE			●	
CHECK LIMIT POSITION				●
GEAR TRAIN WEAR				●

\* If Installed.

# Section 10: Appendix A

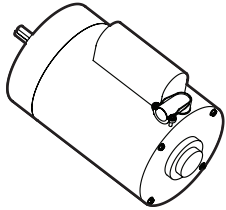
## Operator Parts Breakdown



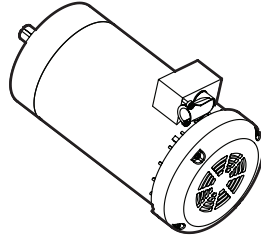
Item	Part Number	Description	Qty
1	111858.0001	ELEC BOX, 1/2HP, 1 PH	1
	111858.0002	ELEC BOX, 3/4HP, 1 PH	1
	111858.0003	ELEC BOX, 1HP, 1 PH	1
	111858.0004	ELEC BOX, 1/2HP, 3 PH	1
	111858.0005	ELEC BOX, 3/4-1HP, 3 PH	1
	111858.0006	ELEC BOX, 575V	1
2	111518.0001	BRACKET, ELEC BOX, RHXT	2
3	111515.0001	FRAME, RHXT	1
4	111421.0001	LIMIT MODULE	1
5	111856.0001	SHAFT ASSY, OUTPUT	1
6	111584.0060	CHAIN, #41 X 60P, LOOP	1
7	111583.0001	CLUTCH ASSY	1
8	111857.0001	BRAKE ASSY	1
9	111503.0001	GEAR REDUCER, 20:1	1
10		MOTOR, SEE PAGE 10.2	1

# Section 10: Appendix A

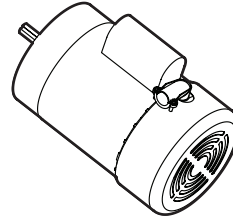
## Motor Options



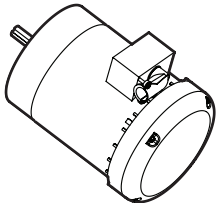
111502.0001—1/2HP, 1 PH, ODP  
 111502.0002—3/4HP, 1 PH, ODP  
 111502.0003—1HP, 1 PH, ODP  
 111502.0004—1/2HP, 3 PH, ODP  
 111502.0005—3/4HP, 3 PH, ODP  
 111502.0006—1HP, 3 PH, ODP  
 111502.0007—1/2HP, 575V, ODP  
 111502.0008—3/4HP, 575V, ODP  
 111502.0009—1HP, 575V, ODP



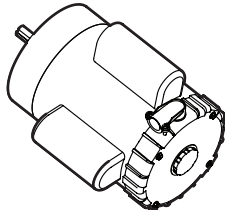
111548.0001—3HP, 3 PH, FC  
 111548.0002—3HP, 575V, FC



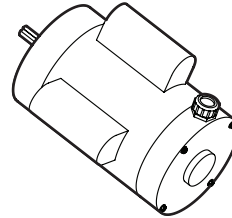
111694.0001—1/2HP, 1 PH, TEFC  
 111694.0002—1HP, 1 PH, TEFC



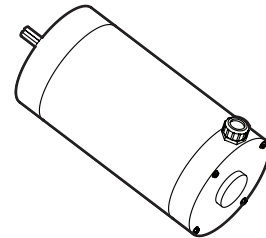
111695.0001—1/2HP, 3 PH, TEFC  
 111695.0002—1HP, 3 PH, TEFC  
 111695.0003—1HP, 575V, TEFC



111696.0001—1/2HP, 1 PH, TENV  
 111696.0002—1/2HP, 3 PH, TENV  
 111696.0003—1HP, 3 PH, TENV  
 111696.0004—1HP, 575V, TENV



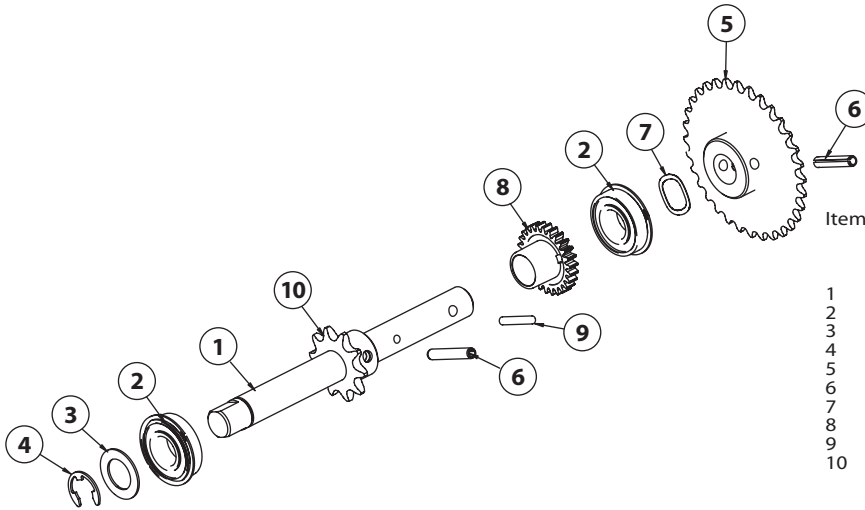
111697.0001—1/2HP, 1 PH, N4  
 111697.0002—1HP, 1 PH, N4  
 111697.0003—1/2HP, 3 PH, N4  
 111697.0004—1HP, 3 PH, N4  
 111697.0004—1HP, 575V, N4



111698.0001—3HP, 3 PH, N4

# Appendix A (continued)

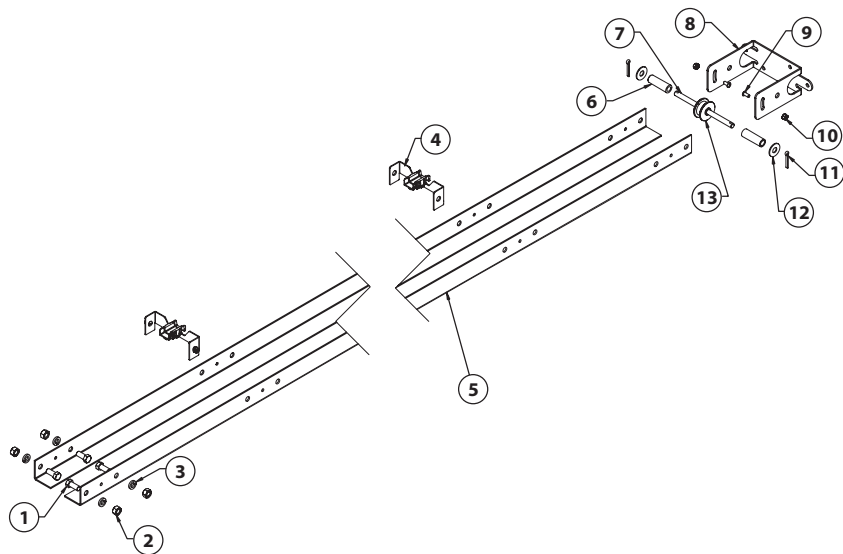
## Output Shaft Parts Breakdown



Item	Part Number	Description	Qty
<b>111856.0001 SHAFT ASSY, OUTPUT, TROLLEY</b>			
1	111520.0002	SHAFT, OUTPUT, RHXT	1
2	110695.0001	BEARING, .750" ID	2
3	110819.0003	WASHER, .770" ID	1
4	111382.0001	RING, RTNG, HIGH GRIP STR	1
5	111611.0001	SPROCKET, #41, 1/2P, 12T	1
6	110313.0004	PIN, SPRING, .250" DIA X 1.50"L	2
7	110818.0004	WASHER, WAVE SPRING, .780" ID	1
8	111073.0001	GEAR, 26T, LIMIT	1
9	110881.0001	PIN, DOWEL .188 X 1.13/1.00	1
10	110739.0002	SPROCKET, 10T, #41 CH, 1/2P, OD	1
	111611.0002	SPROCKET, #41, 1/2P, 12T	1

# Appendix A (continued)

## Rail Parts Breakdown

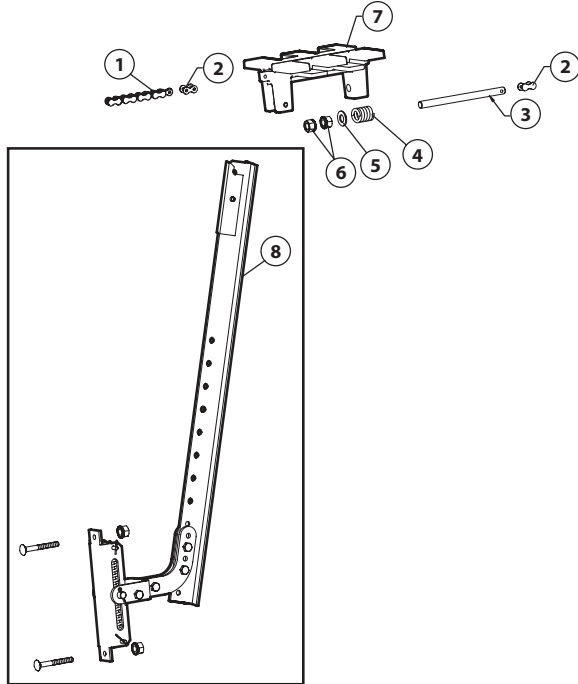


Item	Part Number	Description	Qty
<b>RAIL ASSY, TROLLEY</b>			
1	080105.0708	BOLT, HH, PLD, 7/16"-14 X 1"	4
2	080352.0714	NUT, HEX, PLD, 7/16"-14	4
3	080322.0446	WSHR, LK, PLD, 7/16" X 25/32" OD	4
4	111370.0001	CHAIN GUIDE	2
5	110732.1125	TRACK, 8' DOOR	2
	110732.1149	TRACK, 10' DOOR	2
	110732.1173	TRACK, 12' DOOR	2
	110732.1197	TRACK, 14' DOOR	2
	110732.1221	TRACK, 16' DOOR	2
	110732.1245	TRACK, 18' DOOR	2
	110732.1269	TRACK, 20' DOOR	2
	110732.1317	TRACK, 24' DOOR	2
6	110744.0001	SPACER	2
7	110768.0001	PIN, IDLER	1
8	111078.0001	SPREADER BRACKET	1
9	080019.0001	BOLT, TRK, PLD, 1/4-20 X 9/16"	2
10	086480.1620	NUT, HEX, W/LK WASHER, 1/4-20	2
11	080401.0616	PIN, COTTER	2
12	080302.3240	WASHER, PLAIN, STEEL	2
13	111178.0001	IDLER, FRNT SPREADR w/BUSHING	1



# Appendix A (continued)

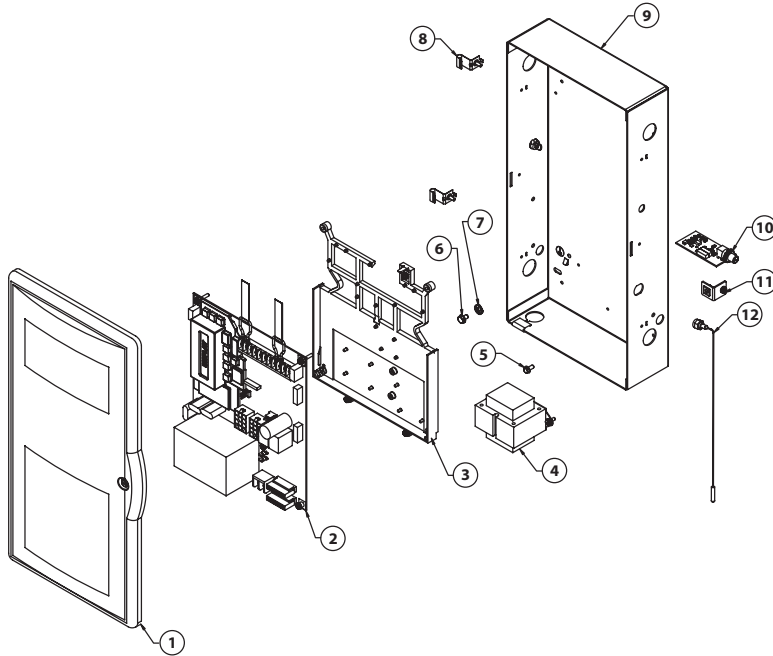
## Carriage/Door Arms Parts Breakdown



Item	Part Number	Description	Qty
<b>TROLLEY CARRIAGE &amp; DOOR ARMS</b>			
1	080839.4951	#65 CHAIN, 1/2 HP	1
	080839.5911	8' DOOR	1
	080839.6871	10' DOOR	1
	080839.7831	12' DOOR	1
	080839.8791	14' DOOR	1
	080839.8791	16' DOOR	1
	080839.9751	18' DOOR	1
	111342.0495	#41 CHAIN, 3/4 & 1 HP	1
	111342.0591	8' DOOR	1
	111342.0591	10' DOOR	1
	111342.0687	12' DOOR	1
	111342.0783	14' DOOR	1
	111342.0879	16' DOOR	1
	111342.0975	18' DOOR	1
	111342.1071	20' DOOR	1
	111342.1263	24' DOOR	1
2	080884.0003	CONNECTING LINK, #41 CHAIN	2
3	110784.0001	ROD, THREADED, 3/8-16	1
4	075064.0000	SPRING, CRG., .796 OD X 1-1/4"	1
5	080302.2626	WASHER, FLAT, PLD, 3/8" X 13/16"	1
6	086480.2416	NUT, HEX, W/LK WSHR, 3/8"-16	2
7	110616.0001	CARRIAGE, TROLLEY	1
8	OPAKDBT.S	DRAWBAR KIT	1

# Appendix A (cont')

## Electric Box Parts Breakdown

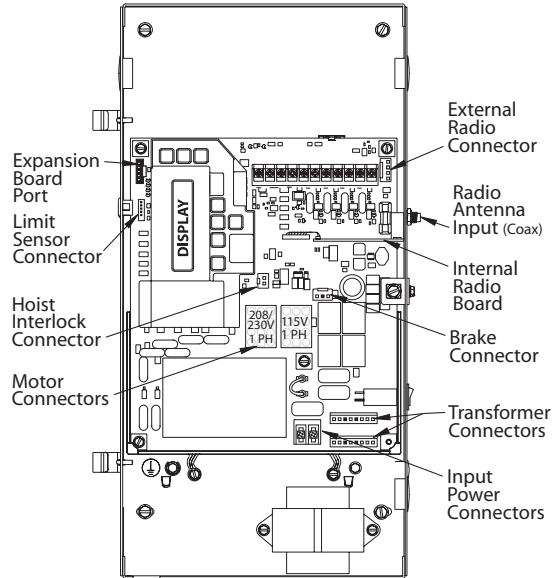


Item	Part Number	Description	Qty
1	111853.0001	COVER ASSY, 1 PHASE	1
	111853.0002	COVER ASSY, 3 PHASE	1
	111853.0003	COVER ASSY, 575V	1
2	111854.0001	CIRCUIT BOARD ASSY, 1 PHASE, 1/2 HP	1
	111854.0002	CIRCUIT BOARD ASSY, 1 PHASE, 3/4 - 1HP	1
	111854.0003	CIRCUIT BOARD ASSY, 3 PHASE, 1/2HP	1
	111854.0004	CIRCUIT BOARD ASSY, 3 PHASE, 3/4 - 1HP	1
	111854.0005	CIRCUIT BOARD ASSY, 575V	1
3	111401.0001	INSULATOR BOARD ASSY	1
4	111087.0001	XFMR, 115/208/230V, 1 PHASE	1
	111087.0002	XFMR, 208/230/460V, 3 PHASE	1
	111087.0003	XFMR, 575V	1
5	8706.E29	SCREW, GROUND, #8-32 X 3/8"	1
6	8706.F29	SCREW, GROUND, #10-32 X 3/8"	1
7	22634A	WASHER, CUP	1
8	110950.0001	HINGE ASSY	2
9	110630.0001	ELECTRIC BOX	1
10	111397.0001	RECEIVER ASSY	1
11	111398.0001	LATCH ASSY	1
12	111352.0001	ANTENNA ASSY	1
NS	111405.0001	SPARE FUSE KIT	1

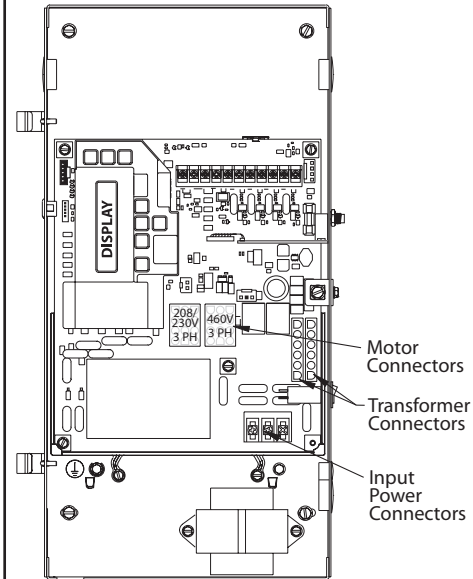
# Appendix A (cont')

## Electric Box Layout

### Single Phase



### Three Phase



# Section 10: Appendix B

## Screw Terminal Assignments

INPUT	FUNCTION	CONNECTION TYPE
<b>11-POSITION TERMINAL BLOCK</b> INSIDE ELECTRIC BOX	OPEN	Causes door to open if not at Up Limit. Causes a closing door to reverse.
	CLOSE	Causes door to close if not at Down Limit.
	STOP	Causes a moving door to stop. Prevents the operator from running.
	GND	Common ground connection for Open, Close, Stop & 1-Btn Inputs.
	1-BTN	Causes door to open if not at Up Limit or Mid-Stop Limit. Causes door to close if at Up Limit or Mid-Stop Limit. Causes door to stop if opening. Causes a closing door to reverse.
	ODC STB	Reverses a closing door if photocell beam is blocked. NOTE: STB's must be enabled in Calibration Mode.
	ODC STB	Reverses a closing door if photocell beam is blocked. NOTE: STB's must be enabled in Calibration Mode.
	N-O REVERSE	Causes a closing door to reverse. NOTE: Will not open a stopped door.
	N-O REVERSE	Causes a closing door to reverse. NOTE: Will not open a stopped door.
	EXT INTLK	Causes a moving door to stop. Prevents the operator from running when contact is open. Operates even if microcontroller is non-functional.
	EXT INTLK	Causes a moving door to stop. Prevents the operator from running when contact is open. Operates even if microcontroller is non-functional.
<b>2-POSITION TERMINAL BLOCK</b> (INSIDE ELECTRIC BOX)	L1 / L1	Power to RSX™ operator.
	N / L2	Power to RSX™ operator.
<b>RADIO AND ACCESSORIES PIGTAIL</b>	PWR	Power for radio & other accessories. +20 to +40VDC, fused at 250mA (F1).
	RAD (Radio Input Control)	Causes door to open if not at Up Limit or Mid-Stop Limit. Causes door to close if at Up Limit or Mid-Stop Limit. Causes a closing door to reverse.
	GND	Common ground connection for PWR and RAD terminals.
<b>PLUG CONNECTIONS</b> INSIDE ELECTRIC BOX	EXPANSION PORT	Connects accessory modules to RSX™ operator.
	TRANSFORMER	Connects main transformer to control board.
	BRAKE	Connects brake solenoid to control board.
	MOTOR	Connects motor and capacitor to control board.
	HOIST INTLK	Causes moving door to stop. Prevents the operator from running. Operates even if microcontroller is non-functional.
	LIMIT SENSOR	Causes door to stop at top and bottom of normal travel.

# Section 10: Appendix C

## Run Code Displays

Condition Code	DISPLAY	Condition Code Description
0C	IDLE > DOWN LIMIT	<b>STANDING BY AT DOWN LIMIT (NOTE: THIS MESSAGE IS DISPLAYED IF BOTH LIMITS ARE ACTIVE)</b>
0D	IDLE > UP LIMIT	STANDING BY AT UP LIMIT
0E	IDLE > MID STOP	STANDING BY AT MID-STOP LIMIT
0F	IDLE > NO LIMIT	STANDING BY BETWEEN LIMITS
10	<b>OPENING &gt; OPEN BTN</b>	<b>OPENING FROM OPEN BUTTON</b>
11	OPENING > ONE BTN	OPENING FROM 1 BUTTON
12	OPENING > RADIO	OPENING FROM RADIO
13	OPENING > AUX OPEN	OPENING FROM AUXILIARY OPEN INPUT
14	OPENING > OPEN KEY	OPENING FROM KEYPAD OPEN KEY
20	<b>CLOSING &gt; CLOSE PB</b>	<b>CLOSING FROM CLOSE BUTTON</b>
21	CLOSING > ONE BTN	CLOSING FROM 1 BUTTON
22	CLOSING > RADIO	CLOSING FROM RADIO
24	CLOSING > CLOSE KP	CLOSING FROM KEYPAD CLOSE KEY
2A	<b>CLOSING &gt; TCM CLS</b>	<b>CLOSING FROM TIMER CLOSE MODULE</b>
2B	CLOSING > FDM CLS	CLOSING FROM FORE DOOR MODULE
30	<b>HALT &gt; WALL BUTTON</b>	<b>GDO STOPPED BECAUSE STOP OR OPEN BUTTON WAS ACTIVATED, POSSIBLY STARTING A REVERSAL</b>
31	HALT > ONE BUTTON	GDO STOPPED BECAUSE 1 BUTTON WAS ACTIVATED, POSSIBLY STARTING A REVERSAL
32	HALT > RADIO	GDO STOPPED BECAUSE RADIO INPUT WAS ACTIVATED, STARTING A REVERSAL
33	HALT > AUX. OPEN	GDO STOPPED BECAUSE AUXILIARY OPEN INPUT WAS ACTIVATED, STARTING A REVERSAL
34	HALT > KEYPAD KEY	GDO STOPPED BECAUSE KEYPAD STOP OR OPEN KEY WAS ACTIVATED, POSSIBLY STARTING A REVERSAL
35	HALT > N-O SAFETY	GDO STOPPED BECAUSE N-O REVERSING INPUT WAS ACTIVATED, STARTING A REVERSAL
36	HALT > ODC STB	GDO STOPPED BECAUSE ODC STB WAS BLOCKED, STARTING A REVERSAL
37	HALT > N-C SAFETY	GDO STOPPED BECAUSE N-C REVERSING INPUT WAS ACTIVATED, STARTING A REVERSAL
38	HALT > MON. EDGE	GDO STOPPED BECAUSE MONITORED EDGE SENSOR INPUT WAS ACTIVATED, STARTING A REVERSAL
39	HALT > DOOR FORCE	GDO STOPPED BECAUSE THE FORCE REQUIRED TO OPERATE THE DOOR WAS TOO HIGH, POSSIBLY STARTING A REVERSAL
3A	<b>HALT &gt; LOSS OF C/C</b>	<b>GDO STOPPED BECAUSE CONSTANT CONTACT ON CONTROL REMOVED BEFORE REACHING A LIMIT, POSSIBLY STARTING A REVERSAL</b>
3B	HALT > SHUTDOWN	GDO STOPPED BECAUSE THE GDO DETECTED A FAULT SUCH AS AN OPEN INTERLOCK, OVERHEATED MOTOR, ETC.
3C	HALT > DOWN LIMIT	GDO STOPPED BECAUSE IT REACHED THE DOWN LIMIT
3D	HALT > UP LIMIT	GDO STOPPED BECAUSE IT REACHED THE UP LIMIT
3E	HALT > MID STOP	GDO STOPPED BECAUSE IT REACHED THE MID-STOP LIMIT
3F	HALT > MODULE FAIL	GDO STOPPED BECAUSE AN EXPANSION MODULE WAS NOT WORKING PROPERLY
40	<b>REV &gt; OPEN BUTTON</b>	<b>GDO REVERSED BECAUSE THE OPEN BUTTON WAS ACTIVATED</b>
41	REV > ONE BUTTON	GDO REVERSED BECAUSE THE 1 BUTTON WAS ACTIVATED
42	REV > RADIO	GDO REVERSED BECAUSE THE RADIO INPUT WAS ACTIVATED
43	REV > AUX OPEN	GDO REVERSED BECAUSE THE AUXILIARY OPEN INPUT WAS ACTIVATED
44	REV > OPEN KEY	GDO REVERSED BECAUSE THE KEYPAD OPEN KEY WAS ACTIVATED
45	REV > N-O SAFETY	GDO REVERSED BECAUSE THE N-O REVERSING INPUT WAS ACTIVATED

## Error Code Displays

# Section 10: Appendix C

Condition Code	DISPLAY	Condition Code Description
46	REV > ODC STB	GDO REVERSED BECAUSE THE ODC STB WAS BLOCKED
47	REV > N-C SAFETY	GDO REVERSED BECAUSE THE N-C REVERSING INPUT WAS ACTIVATED
48	REV > MON. EDGE	GDO REVERSED BECAUSE THE MONITORED EDGE SENSOR WAS ACTIVATED
49	REV > DOOR FORCE	GDO REVERSED BECAUSE THE FORCE REQUIRED TO CLOSE THE DOOR WAS TOO HIGH
<b>4A</b>	<b>REV &gt; LOSS OF C/C</b>	<b>GDO REVERSED BECAUSE CONSTANT CONTACT ON THE CONTROL WAS REMOVED BEFORE REACHING THE DOWN LIMIT</b>
4B	REV > MAX RUN TMR	GDO REVERSED BECAUSE THE CLUTCH SLIPPED OR SOME OTHER FAULT OCCURRED THAT ALLOWED THE GDO TO RUN TOO LONG
4F	REV > EXP MOD FAIL	GDO REVERSED BECAUSE AN EXPANSION MODULE WAS NOT WORKING PROPERLY
<b>50</b>	<b>STOP &gt; HOT MOTOR</b>	<b>GDO STOPPED BECAUSE THE MOTOR WAS OVERHEATED</b>
51	STOP > OPEN MRT	GDO STOPPED BECAUSE THE CLUTCH SLIPPED OR SOME OTHER FAULT OCCURRED THAT ALLOWED THE GDO TO RUN OPEN TOO LONG
52	STOP > CLOSE MRT	GDO STOPPED BECAUSE THE CLUTCH SLIPPED OR SOME OTHER FAULT OCCURRED THAT ALLOWED THE GDO TO RUN DOWN TOO LONG
57	STOP > OPEN INTLK	GDO STOPPED BECAUSE THE HOIST INTERLOCK OR EXTERNAL INTERLOCK IS OPEN
58	STOP > WRONG GDO	GDO STOPPED BECAUSE THE BOARD IS SET FOR JACKSHAFT MODE, BUT INSTALLED IN A TROLLEY OPERATOR
59	STOP > DOOR FORCE	GDO STOPPED BECAUSE THE FORCE REQUIRED TO OPEN THE DOOR WAS TOO HIGH
<b>5A</b>	<b>STOP &gt; WRONG LIMIT</b>	<b>GDO STOPPED BECAUSE THE UP LIMIT ACTIVATED WHEN CLOSING OR THE DOWN LIMIT ACTIVATED WHEN OPENING</b>
5B	STOP > WRONG DIR	GDO STOPPED BECAUSE THE DOOR MOVED IN THE WRONG DIRECTION
5C	STALL > DOWN LIMIT	GDO STOPPED BECAUSE IT COULDN'T LEAVE THE DOWN LIMIT DUE TO A SLIPPING CLUTCH OR OTHER PROBLEM
5D	STALL > UP LIMIT	GDO STOPPED BECAUSE IT COULDN'T LEAVE THE UP LIMIT DUE TO A SLIPPING CLUTCH OR OTHER PROBLEM
5E	STALL > MID-STOP	GDO STOPPED BECAUSE IT COULDN'T LEAVE THE MID-STOP LIMIT DUE TO A SLIPPING CLUTCH OR OTHER PROBLEM
<b>60</b>	<b>CHECK STOP BTN</b>	<b>GDO WON'T RUN BECAUSE THE STOP BUTTON IS ACTIVE</b>
61	TCM DISABLED	TIMER CLOSE WON'T WORK BECAUSE NO SAFETIES ARE ENABLED
62	NO RADIO >> C/C	RADIO INPUT WON'T WORK WITH OPEN OR CLOSE FUNCTION IN CONSTANT CONTACT MODE
63	CHECK AUX OPEN	GDO WON'T CLOSE BECAUSE AUXILIARY OPEN INPUT IS ACTIVE
64	CHECK STOP KEY	GDO WON'T RUN BECAUSE THE KEYPAD STOP KEY IS ACTIVE
65	CHECK N-O SAFETY	GDO WON'T CLOSE BECAUSE THE N-O REVERSING IS ACTIVE
66	CHECK ODC STB	GDO WON'T CLOSE BECAUSE THE ODC STB IS BLOCKED
67	CHECK N-C SAFETY	GDO WON'T CLOSE BECAUSE THE N-C REVERSING INPUT IS ACTIVE
68	CHECK MON. EDGE	GDO WON'T CLOSE BECAUSE THE MONITORED EDGE SENSOR IS ACTIVE
69	OVERHEATED MOTOR	GDO WON'T RUN BECAUSE THE MOTOR IS OVERHEATED
<b>6A</b>	<b>POWER WIRING ERROR</b>	<b>GDO WON'T RUN BECAUSE</b>
6B	FIRE DOOR SHTDN	GDO WON'T RUN BECAUSE OF LOSS OF POWER
6C	NO RUN > DOWN LIM	GDO WON'T CLOSE BECAUSE ITS ALREADY AT THE DOWN LIMIT
6D	NO RUN > UP LIMIT	GDO WON'T OPEN BECAUSE ITS ALREADY AT THE UP LIMIT
6E	NO RUN > MID STOP	GDO WON'T RUN BECAUSE ITS AT OR ABOVE THE MID-STOP LIMIT & CAN'T RUN UP & A REVERSING INPUT IS PREVENTING IT FROM CLOSING
6F	EXP MODULE FAIL	GDO WON'T RUN BECAUSE AN EXPANSION MODULE FAILURE IS PREVENTING IT

# Section 10: Appendix C

## Error Codes Displays (continued)

Condition Code	DISPLAY	Condition Code Description
<b>70</b>	<b>BOARD FAILURE 70</b>	<b>CONTROL BOARD FAILURE 70, CONTACT FACTORY TECHNICAL SERVICE DEPT.</b>
71	BOARD FAILURE 71	CONTROL BOARD FAILURE 71, CONTACT FACTORY TECHNICAL SERVICE DEPT.
74	BOARD FAILURE 74	CONTROL BOARD FAILURE 74, CONTACT FACTORY TECHNICAL SERVICE DEPT.
75	BOARD FAILURE 75	CONTROL BOARD FAILURE 75, CONTACT FACTORY TECHNICAL SERVICE DEPT.
76	BOARD FAILURE 76	CONTROL BOARD FAILURE 76, CONTACT FACTORY TECHNICAL SERVICE DEPT.
77	BOARD FAILURE 77	CONTROL BOARD FAILURE 77, CONTACT FACTORY TECHNICAL SERVICE DEPT.
<b>80</b>	<b>BOARD FAILURE 80</b>	<b>CONTROL BOARD FAILURE 80, CONTACT FACTORY TECHNICAL SERVICE DEPT.</b>
81	BOARD FAILURE 81	CONTROL BOARD FAILURE 81, CONTACT FACTORY TECHNICAL SERVICE DEPT.
82	BOARD FAILURE 82	CONTROL BOARD FAILURE 82, CONTACT FACTORY TECHNICAL SERVICE DEPT.
83	BOARD FAILURE 83	CONTROL BOARD FAILURE 83, CONTACT FACTORY TECHNICAL SERVICE DEPT.
84	BOARD FAILURE 84	CONTROL BOARD FAILURE 84, CONTACT FACTORY TECHNICAL SERVICE DEPT.
85	EXP PORT PROBLEM	EXPANSION PORT IS SHORT CIRCUITED, TRY DISCONNECTING EXPANSION MODULES OR CONTACT FACTORY TECHNICAL SERVICE DEPT.
86	BOARD FAILURE 86	CONTROL BOARD FAILURE 86, DISCONNECT EXPANSION MODULES. IF NO CHANGE, CONTACT FACTORY TECHNICAL SERVICE DEPT.
87	IEM FAILURE	RESERVED--NOT CURRENTLY USED
88	TCM FAILURE	TIMER CLOSE MODULE (TCM) HAS FAILED
89	FDM FAILURE	FIRE DOOR MODULE (FDM) HAS FAILED
<b>8A</b>	<b>AOM FAILURE</b>	<b>AUXILIARY OUTPUT MODULE (AOM) HAS FAILED</b>
8B	SPARE MOD FAILURE	RESERVED--NOT CURRENTLY USED
8C	LOW SYSTEM VOLTS	POWER SUPPLY LINE VOLTAGE LOW
8D	HI SYSTEM VOLTS	POWER SUPPLY LINE VOLTAGE HIGH
8E	REV INTERRUPTED	GDO LOST POWER OR ENCOUNTERED ANOTHER PROBLEM DURING THE REVERSAL PROCESS, REVERSAL IS COMPLETING NOW
8F	LIMIT MOD. FAIL	GDO WON'T RUN, LIMIT MODULE HAS FAILED
<b>90</b>	<b>DIAGNOSTIC MODE</b>	<b>GDO IS IN DIAGNOSTIC MODE, NORMAL FUNCTIONS ARE NOT ALLOWED</b>
A0	OPEN BTN BAD > PU	OPEN & CLOSE BUTTONS WON'T WORK, THE OPEN BUTTON WAS ACTIVE WHEN THE GDO WAS POWERED-UP
A1	CLOSE BTN BAD > PU	OPEN & CLOSE BUTTONS WON'T WORK, THE CLOSE BUTTON WAS ACTIVE WHEN THE GDO WAS POWERED-UP
A2	ONE BTN WON'T WORK > PU	1 BUTTON WON'T WORK, THE 1 BUTTON WAS ACTIVE WHEN THE GDO WAS POWERED-UP
A3	RADIO BAD > PWR UP	RADIO INPUT WON'T WORK, THE RADIO INPUT WAS ACTIVE WHEN THE GDO WAS POWERED-UP
A4	AUX OPEN BAD > PU	AUXILIARY OPEN INPUT WON'T WORK, THE AUXILIARY OPEN INPUT WAS ACTIVE WHEN THE GDO WAS POWERED-UP
A5	OPEN KEY BAD > PU	KEYPAD OPEN & CLOSE KEYS WON'T WORK, THE OPEN KEY WAS ACTIVE WHEN THE GDO WAS POWERED-UP
A6	CLOSE KEY BAD > PU	KEYPAD OPEN & CLOSE KEYS WON'T WORK, THE CLOSE KEY WAS ACTIVE WHEN THE GDO WAS POWERED-UP
A7	MULT KEYS BAD > PU	1 OR MORE KEYPAD CALIBRATION KEYS WON'T WORK, 1 OR MORE WERE ACTIVE WHEN THE GDO WAS POWERED-UP
AA	TCM BAD > POWER UP	RESERVED--NOT CURRENTLY USED
AB	FDM BAD > POWER UP	RESERVED--NOT CURRENTLY USED
<b>B0</b>	<b>OPENING &gt; XMTR #</b>	<b>OPENING FROM TRANSMITTER # ___</b>
B1	CLOSING > XMTR #	CLOSING FROM TRANSMITTER # ___
B2	HALT > XMTR #	HALT FROM TRANSMITTER # ___
B3	NO XMTR > CC	NO CONTROL FROM TRANSMITTER, CONSTANT CONTACT EMPLOYED AT LOCAL CONTROL

**The Genuine. The Original.**



FOR ASSISTANCE, CALL 800-275-6187



## TORQUE LIMITER INSTALLATION SUPPLEMENT FOR ALL HP RATINGS RHX COMMERCIAL-INDUSTRIAL DOOR OPERATOR.

### NOT FOR RESIDENTIAL USE

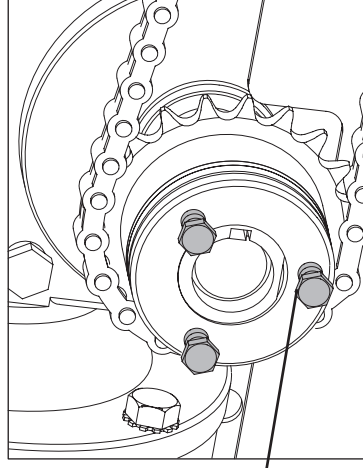
**This supplement instruction is to be used in combination with the standard accompanying RHX<sup>®</sup> Installation Manual. This supplement contains adjustment and installation instruction and illustrated parts breakdowns which specify parts included in the Torque Limiter Kit.**

**IMPORTANT:** Prior to installing or operating an RHX<sup>®</sup> Commercial-Industrial Door Operator, carefully read the RHX<sup>®</sup> Installation Manual and any other instructions and warnings accompanying the unit.

### Adjustment Torque Limiter

The RHX<sup>®</sup> Clutch does not require any disassembly to adjust.

- 1) All adjustments should be made in very small amounts (e.g. turning adjustment bolts 1/2 of a flat at a time).
- 2) When making adjustments, be sure to turn all 3 adjustment bolts an equal amount. **Fig 12.**
  - To increase tension, turn adjustment bolts clockwise.
  - To decrease tension, turn adjustment bolts counter-clockwise.

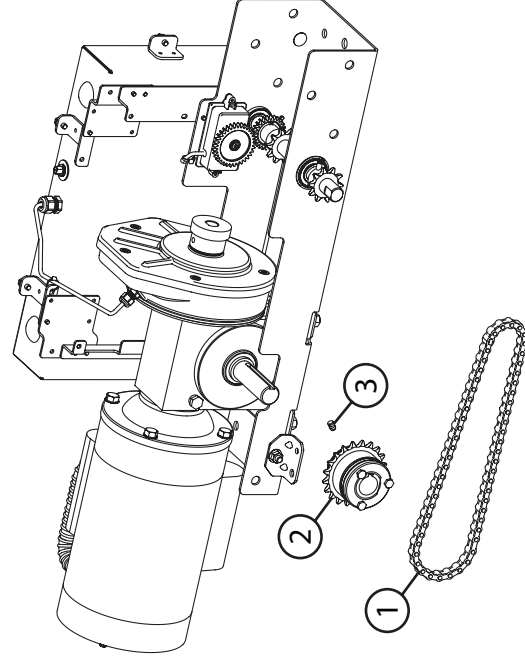


ADJUSTMENT BOLTS

### Replacing Torque Limiter

*While the Trolley Unit is shown, this is typical of all torque limiter applications and all follow the same basic procedure.*

- 1) Turn off power to the operator. (It is highly recommended that a approved Tag Out/Lock Out procedure be used during any maintenance of the operator.)
- 2) Loosen set screws on the torque limiter and the limit shaft gear.
- 3) Remove the torque limiter, limit shaft gear and chain as a unit.
- 4) Make sure key is seated in the keyway.
- 5) With the chain looped around the new torque limiter and the limit shaft gear, slide all as a unit back onto their respective shafts. Once started onto their shafts, make sure the torque limiter is aligned with the key and slide fully into position.
- 6) Make sure the torque limiter and limit shaft gear are lined up so the chain is perpendicular to the shafts.
- 7) Tighten set screws.



FOR ASSISTANCE, CALL 800-275-6187

**RHX™**  
HEAVY DUTY COMMERCIAL OPERATOR

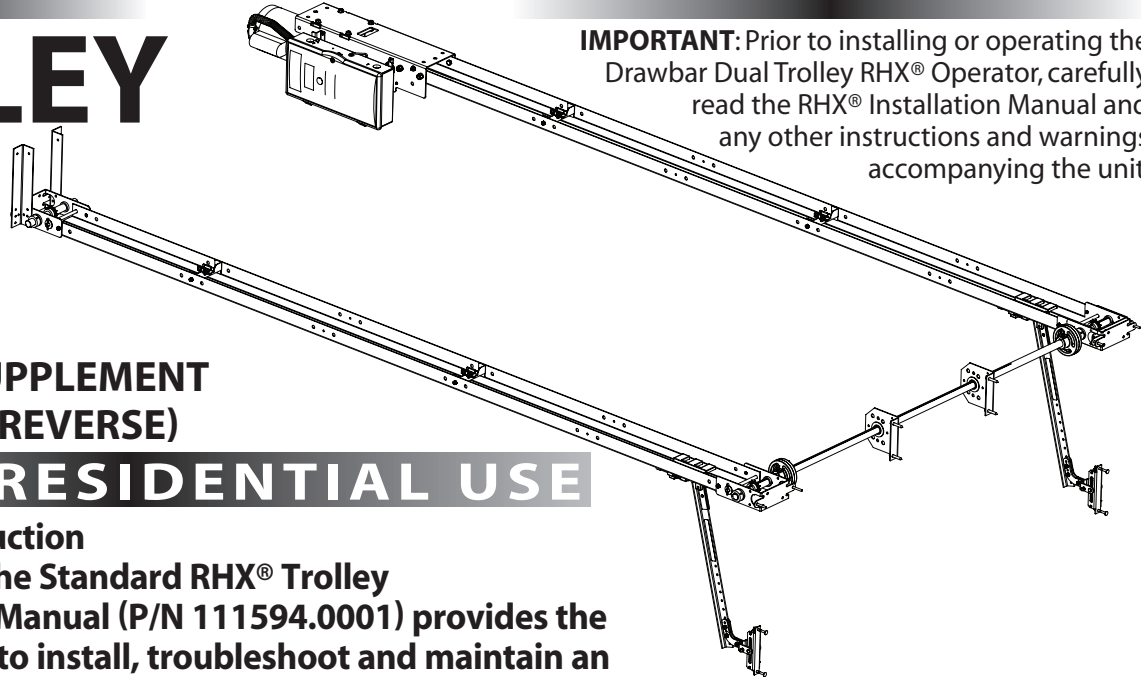
The Genuine. The Original.  
**OVERHEAD DOOR®**

# TROLLEY DUAL TROLLEY VERSION

**INSTALLATION SUPPLEMENT  
(SIDE MOUNT ON REVERSE)**

**NOT FOR RESIDENTIAL USE**

**This Installation Instruction  
in combination with the Standard RHX® Trolley  
Operator Installation Manual (P/N 111594.0001) provides the  
information required to install, troubleshoot and maintain an  
RHX® Commercial/Industrial Dual Trolley Drawbar Type Door Operator.**



**IMPORTANT:** Prior to installing or operating the Drawbar Dual Trolley RHX® Operator, carefully read the RHX® Installation Manual and any other instructions and warnings accompanying the unit.

# Dual Trolley Installation

(SUPPLEMENT TO SECTION 4 OF THE ACCOMPANYING RHX® INSTALLATION MANUAL)

## ⚠ CAUTION

Check the working condition of the door before installing the operator. The Door must be free from sticking and binding. If the door is equipped with a latching device, secure the locking bar in the open (unlocked) position. This style operator will act as a latching device when the door is down and therefore the door's lock is no longer needed.

If the door lock is to remain functional, an interlock switch **MUST** be installed which will prevent operation of the door whenever the door lock is engaged. Refer to the Wiring Instructions, section 5.5, of the RHX® Operator Installation Manual for proper connection of the interlock switch.

- 1) Measure the width of the door to determine the center. Make a vertical line above the door, as shown in **Fig. 1**. (If the vertical line is not in line with a door stile, a means of attaching the door bracket to the door must be provided. This can be accomplished by spanning the center of the door's top section (between the top and bottom rail) with a suitable material such as wood or steel).
- 2) Measure the width of the door and divide by 3 in order to determine the center lines for the track assemblies. Mark a vertical line on the header or added attachment material\* as shown in **Fig. 1**.
- 3) Use a level, as shown in **Fig. 2** to find the highest point of travel for the door. Mark this height along your vertical lines.
- 4) Measure at least 5" above the highest point mark and make a horizontal line here.

\* If suitable mounting surface is not already in place( header too short, for example.), securely affix a suitable material (wood, metal plate, angle irons, etc.).

**NOTE:** If an obstruction exists at the point(s) where the header brackets should be mounted, they can be moved as necessary but they must remain an equal distance from their respective sides of the door.

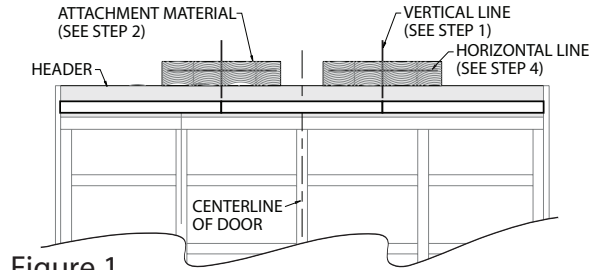


Figure 1

Figure 2

The Drive Track (with operator) is assembled per the RHX® Drawbar Installation Manual except that the new spreader bracket assembly (w/sprocket), Fig. 3, replaces the idler pulley version shown in the manual. The Slave Track will have the new spreader bracket assembly on both ends. Fig. 3 & 4.

- 5) While supporting the operator, raise the drive track into position with the spreader bracket centered on your vertical line and the bottom of the bracket on the horizontal line. Make sure the track is level and attach the bracket to the header using two (2) 1/4" x 1-3/4" lag bolts. Fig. 4.
- 6) Using angle iron (not provided) or fabrication as necessary fasten the operator securely to the framework of the building.
- 7) Position the Drive Track Carriage within a few feet of the Spreader Bracket.
- 8) Slide Shaft Support Brackets onto the dual trolley shaft. Fig. 5. Raise and support the shaft above door opening and align with the drive track sprocket.
- 9) Slide coupling halves onto the dual trolley shaft and the sprocket shaft of the drive track. Insert the keys and slide the coupling halves over their keys. Tighten the set screws. Rotate the sprocket shaft as needed to line up coupling bolt slots and bolt the coupling halves together. Fig. 6.
- 10) Equally space the shaft support brackets and using a level, attach them to the wall.
- 11) Assemble the Slave Track Assembly.
- 12) Assemble the remaining coupling between the dual trolley shaft and sprocket shaft of the slave track. Insert the coupling bolts and nuts but **make them finger tight only**.

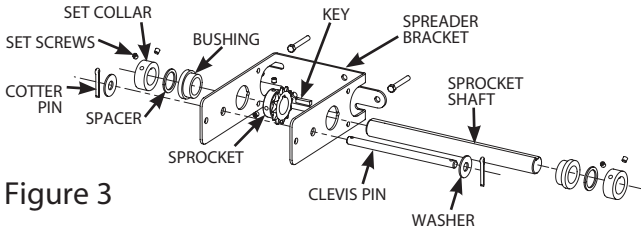


Figure 3

Figure 4

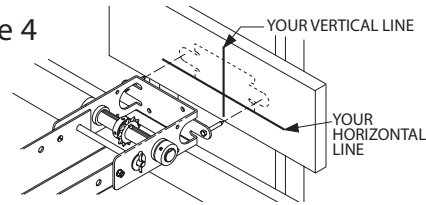


Figure 5

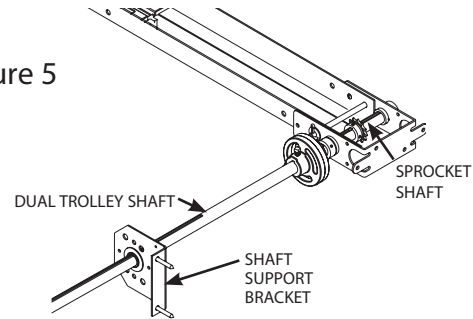
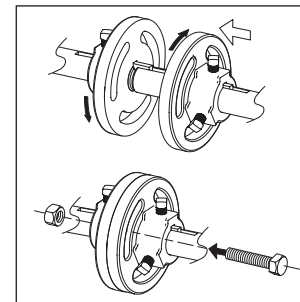


Figure 6



## Connection to the Door

- 1) Pull down on the drawbar arm locking sleeves and attach drawbars to carriages.
- 2) Position the door brackets on the door so that they are directly under the tracks and **even with or above the highest door rollers, Fig. 7a**. Measure to make sure they are both the same distance from the top of the door.
- 3) **For wood doors** fasten the door bracket to the door using two 1/4" -20 X 2-1/4" carriage bolts and nuts.

**For metal doors** use two 1/4"- 20 self tapping sheet metal screws.

Or as recommended by the door manufacturer.

- 4) Use two (2) 3/8" -16 X 7/8" bolts and nuts to attach the door curved door arm to the straight drawbar arm (see notes).

**NOTE:** Make sure both sets of door arms are attached using the same bolt holes. This is critical to maintaining the balance of the door.

**NOTE:** For operators **without a brake**, use the set of holes that align the drawbar in a near vertical position.

For operators **with a brake** set arms at a 20-30 degree angle. **Fig. 7b**.

**NOTE:** If the door strut interferes with the mounting of the door bracket, position the door bracket below the strut. **DO NOT**, in any way, cut or modify the strut.

- 5) Measure Distance "A" on both rails. They must be equal. Be sure to maintain that measurement while attaching the chain. Be watchful to set equal tension on the chains.

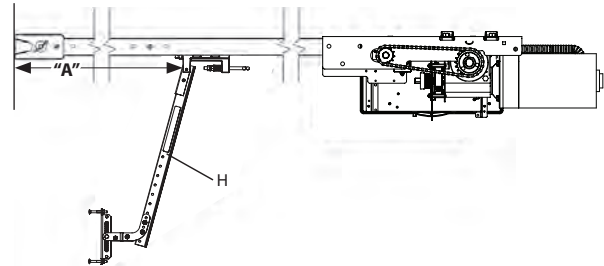
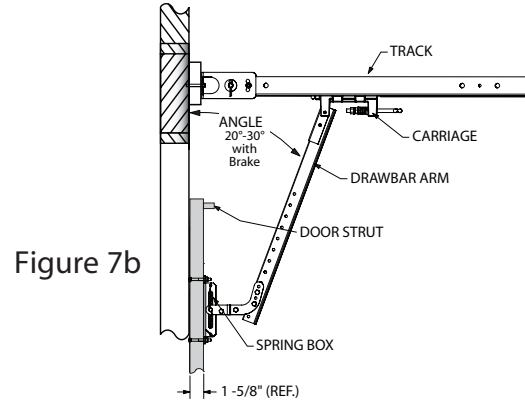
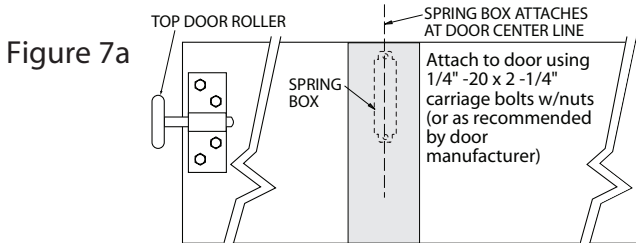
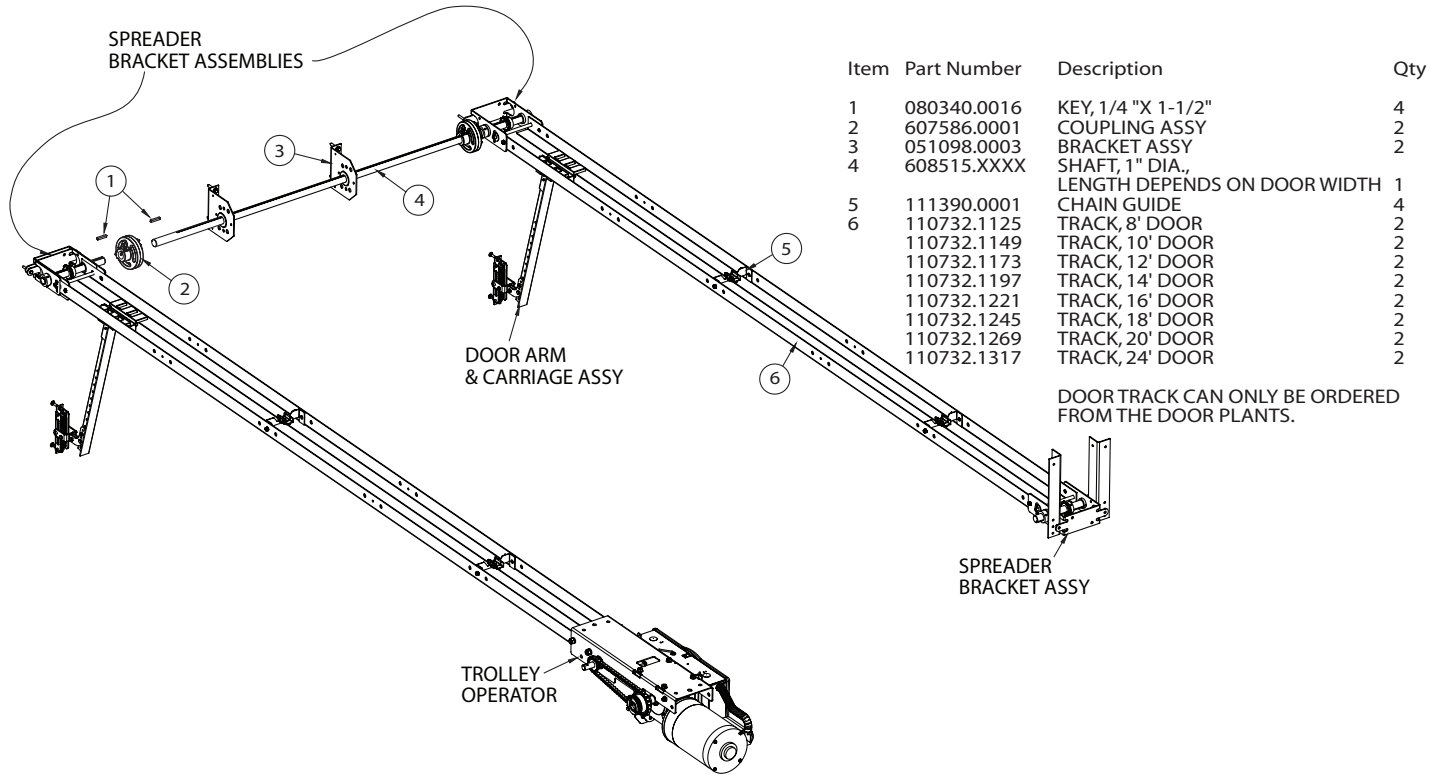


Figure 8

## Dual Track Parts Breakdown

(SUPPLEMENT TO APPENDIX A OF THE ACCOMPANYING RHX® INSTALLATION MANUAL)



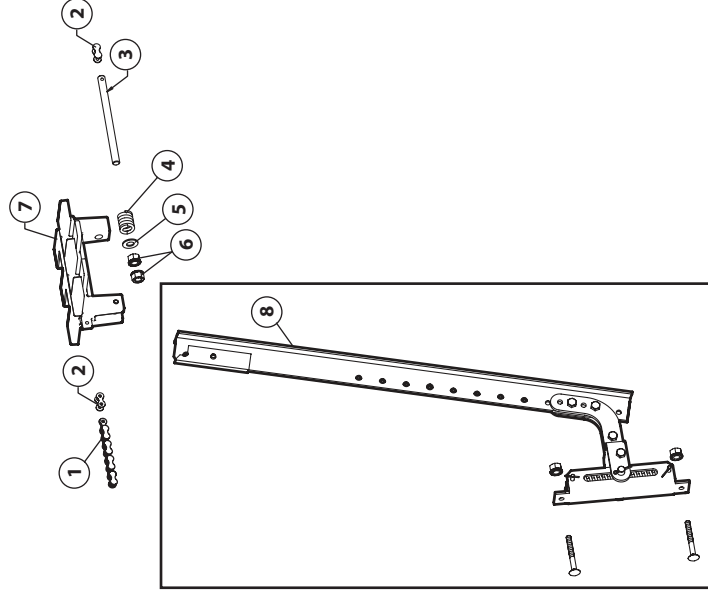
Item	Part Number	Description	Qty
1	080340.0016	KEY, 1/4 "X 1-1/2"	4
2	607586.0001	COUPLING ASSY	2
3	051098.0003	BRACKET ASSY	2
4	608515.XXXX	SHAFT, 1" DIA., LENGTH DEPENDS ON DOOR WIDTH	1
5	111390.0001	CHAIN GUIDE	4
6	110732.1125	TRACK, 8' DOOR	2
	110732.1149	TRACK, 10' DOOR	2
	110732.1173	TRACK, 12' DOOR	2
	110732.1197	TRACK, 14' DOOR	2
	110732.1221	TRACK, 16' DOOR	2
	110732.1245	TRACK, 18' DOOR	2
	110732.1269	TRACK, 20' DOOR	2
	110732.1317	TRACK, 24' DOOR	2

DOOR TRACK CAN ONLY BE ORDERED FROM THE DOOR PLANTS.

## Common Carriage/Door Arms Parts Breakdown

(SUPPLEMENT TO APPENDIX A OF THE ACCOMPANYING RHX® INSTALLATION MANUAL)

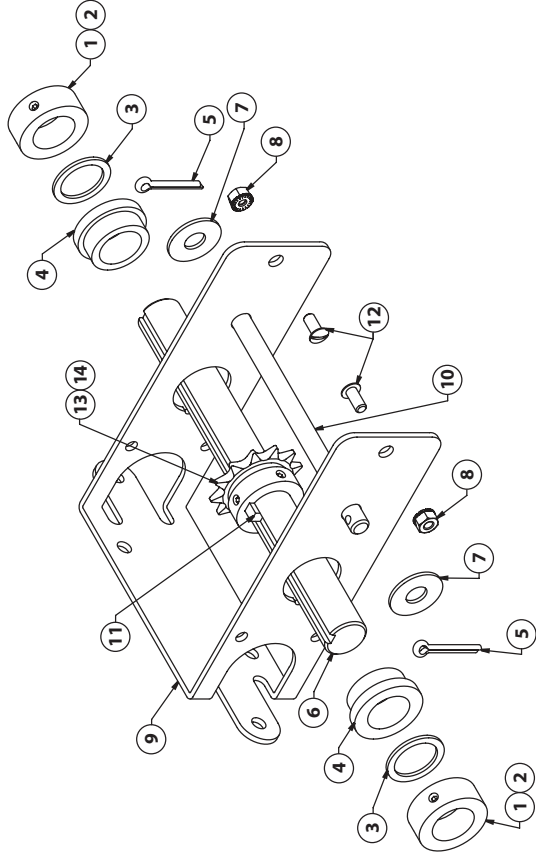
Item	Part Number	Description	Qty
<b>TROLLEY CARRIAGE &amp; DOOR ARMS</b>			
1	080839.4951	#65 CHAIN, 1/2 HP	1
	080839.5911	8' DOOR	1
	080839.6871	10' DOOR	1
	080839.7831	12' DOOR	1
	080839.8791	14' DOOR	1
	080839.9751	16' DOOR	1
		18' DOOR	1
		#41 CHAIN, 3/4 & 1 HP	1
	111342.0495	8' DOOR	1
	111342.0591	10' DOOR	1
	111342.0687	12' DOOR	1
	111342.0783	14' DOOR	1
	111342.0879	16' DOOR	1
	111342.0975	18' DOOR	1
	111342.1071	20' DOOR	1
	111342.1263	24' DOOR	1
2	080884.0003	CONNECTING LINK, #41 CHAIN	2
3	110784.0001	ROD, THREADED, 3/8"-16	1
4	075064.0000	SPRING, CRG, 796 OD X 1-1/4"	1
5	080302.2626	WASHER, FLAT, PLD, 3/8" X 13/16"	1
6	086480.2416	NUT, HEX, W/LK WSHR, 3/8"-16	2
7	110616.0001	CARRIAGE, TROLLEY	2
8	OPAKDBT.S	DRAWBAR KIT	1



# Common Spreader Bracket Parts Breakdown

(SUPPLEMENT TO APPENDIX A OF THE ACCOMPANYING RHX® INSTALLATION MANUAL)

Item	Part Number	Description	Qty
<b>HEADER BRACKET ASSY</b>			
1	604297.4100	COLLAR, SET	2
2	080300.1604	SCREW, SET	4
3	110819.0002	WASHER, PLAIN	2
4	106064.0001	BUSHING, 1"	2
5	080401.0616	PIN, COTTER	2
6	110752.0001	SHAFT, 1" DIA.	1
7	080302.3240	WASHER, FLAT	2
8	086480.1620	LOCKNUT, 1/4"-20	2
9	110734.0001	SPREADER BRACKET	1
10	110768.0001	PIN, IDLER	1
11	080340.0015	KEY, 1/4" X 1"	1
12	080019.0001	TRACK BOLT, 1/4"-20	2
13	110861.0001	SPROCKET, 12T	1
14	080300.1604	SCREW, SET	2





**RHX**<sup>®</sup>  
HEAVY DUTY COMMERCIAL OPERATOR

The Genuine. The Original.

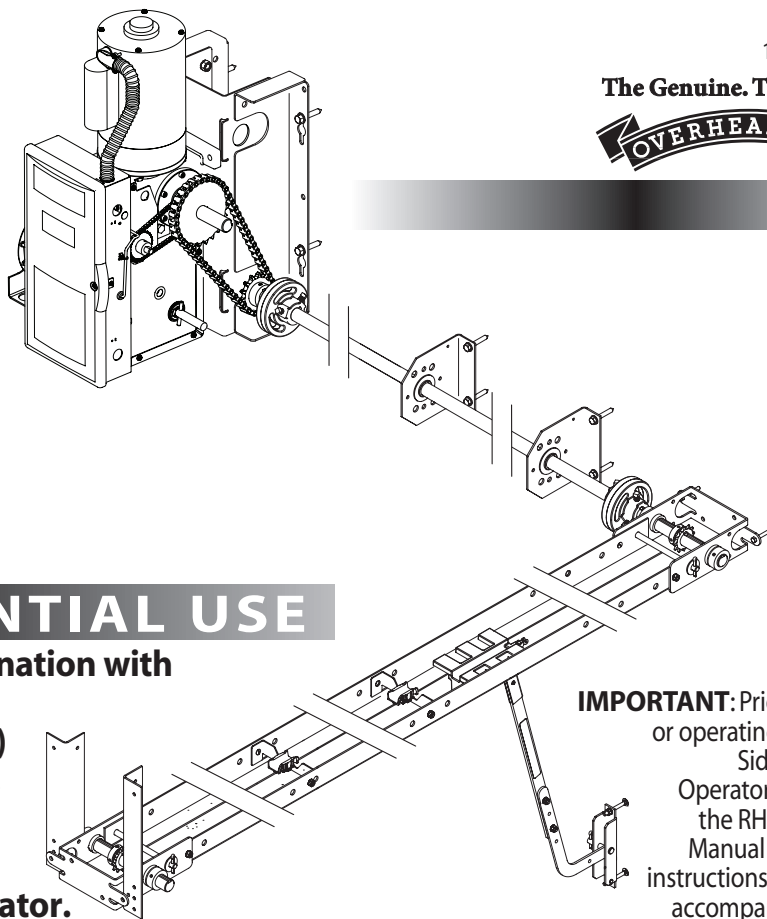


# TROLLEY SIDE MOUNT VERSION

INSTALLATION SUPPLEMENT  
(DUAL TROLLEY ON REVERSE)

**NOT FOR RESIDENTIAL USE**

This Installation Instruction in combination with the Standard RHX<sup>®</sup> Trolley Operator Installation Manual (P/N 111594.0001) provides the information required to install, troubleshoot and maintain an RHX<sup>®</sup> Commercial/Industrial Sidemount Drawbar Type Door Operator.



**IMPORTANT:** Prior to installing or operating the Drawbar Sidemount RHX<sup>®</sup> Operator, carefully read the RHX<sup>®</sup> Installation Manual and any other instructions and warnings accompanying the unit.

# Side Mount Drawbar Installation

(SUPPLEMENT TO SECTION 4 OF THE ACCOMPANYING RHX® INSTALLATION MANUAL)

## ⚠ CAUTION

Check the working condition of the door before installing the operator. The Door must be free from sticking and binding. If the door is equipped with a latching device, secure the locking bar in the open (unlocked) position. This style operator will act as a latching device when the door is down and therefor the door's lock is no longer needed.

If the door lock is to remain functional, an interlock switch **MUST** be installed which will prevent operation of the door whenever the door lock is engaged. Refer to the Wiring Instructions, section 5, of the RHX® Drawbar Installation Manual for proper connection of the interlock switch.

- 1) Measure the width of the door to determine the center. Make a vertical line above the door, as shown in **Fig. 1**. (If the vertical line is not in line with a door stile, a means of attaching the door bracket to the door must be provided. This can be accomplished by spanning the center of the door's top section (between the top and bottom rail) with a suitable material such as wood or steel).
- 2) Prepare for attaching drawbar to header. If suitable mounting surface is not already in place, securely affix a suitable material (wood, metal plate, angle irons, etc.) as shown in **Fig. 1**.
- 3) Center the material on the header.
- 4) Mark the door's vertical center line on this block.
- 5) Use a level, as shown in **Fig. 2** to find the highest point of travel for the door.
- 6) Mark a horizontal line across the vertical line you made on the header at 2-1/2" above the highest point of door travel.

**NOTE:** On torsion spring doors with an uneven number of panels, the operator may be attached to the stile nearest to the center.

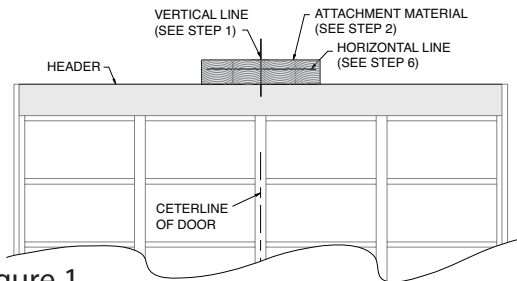


Figure 1

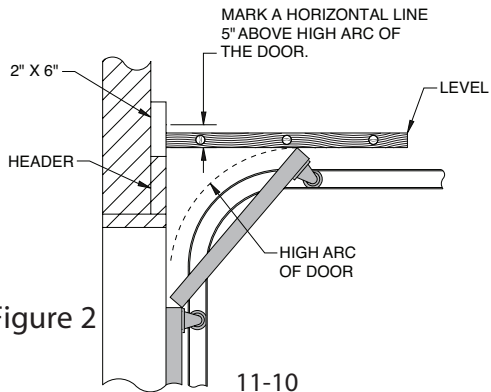


Figure 2

The Drive Track is assembled per the RHX® Drawbar Installation Manual except that the new spreader bracket assembly (w/sprocket), Fig. 3, replaces the idler pulley version shown in the manual.

- 7) Raise the track into position with the header bracket centered on your vertical line and the bottom of the bracket on the horizontal line. Check for level. While supporting the track, attach the spreader bracket to the header using two (2) 1/4" x 1-3/4" lag bolts. Fig. 3.
- 8) Using angle iron (not provided) or fabrication as necessary fasten the operator securely to the framework of the building.
- 9) Slide Shaft Support Brackets onto the extended shaft. Fig. 4.
- 10) Slide coupling halves onto the extended shaft and the sprocket shaft of the spreader bracket assembly. Align the keyway on the sprocket shaft half of the coupling and tighten the set screws. Rotate the extended shaft to align the keyways of the two shafts. Insert the key into the keyways so that it extends into both shafts. Rotate the coupling half and slide it over the key. Tighten set screws.
- 11) Finish coupling the extended shaft to the sprocket shaft using the bolts and nuts supplied with the coupling. Fig. 5.
- 12) Position the shaft support brackets as necessary, ensuring that the shaft remains level, and fasten to the wall.
- 13) Slide the remaining coupling halves onto the operator output shaft and the extended shaft.
- 14) Align the operator output shaft with the extended shaft and fasten the operator to the wall. Couple the operator output shaft to the extended shaft.

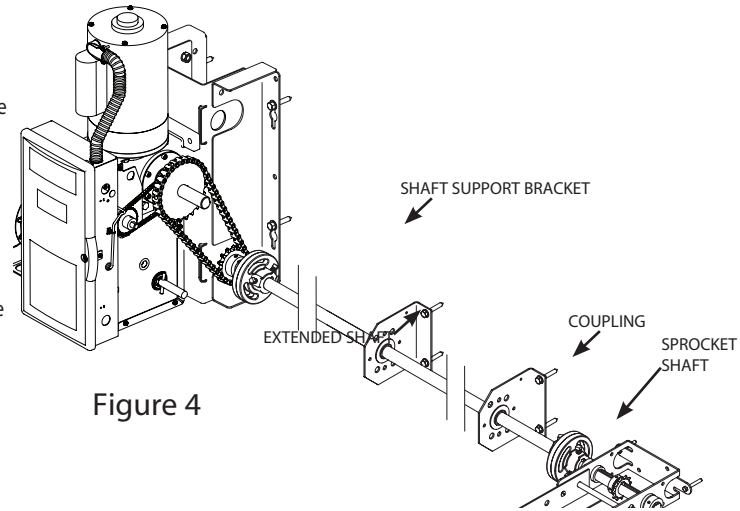


Figure 4

Figure 3

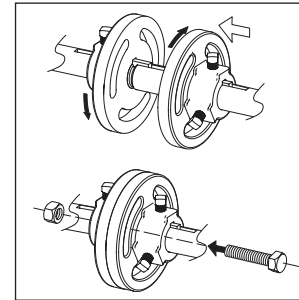
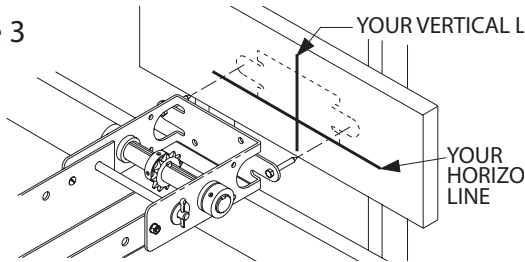


Figure 5

## Connection to the Door

- 1) Pull down on the drawbar arm locking sleeve and attach to carriage.
- 2) Position the spring box on the door as shown in **Fig. 6**, with mounting holes on the door centerline and **even with or above top door roller**.
- 3) **For wood doors** fasten the spring box to the door using two 1/4" -20 X 2-1/4" carriage bolts and nuts.  
**For metal doors** use two 1/4" - 20 self tapping sheet metal screws, or as recommended by the door manufacturer.
- 4) Use two (2) 3/8" -16 X 7/8" bolts and nuts to attach the spring box to the drawbar arm.

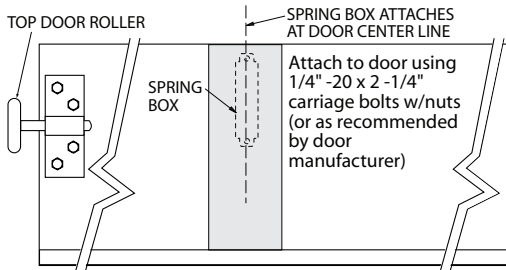


Figure 6

**NOTE:** For operators **without a brake**, use the set of holes that align the drawbar in a near vertical position.

For operators **with a brake** set arms at a 20-30 degree rearward angle. **Fig. 7.**

**NOTE:** If the door strut interferes with the mounting of the spring box, position the spring box below the strut. **DO NOT**, in any way, cut or modify the strut.

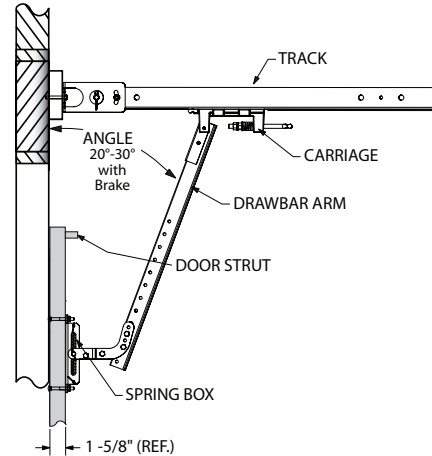
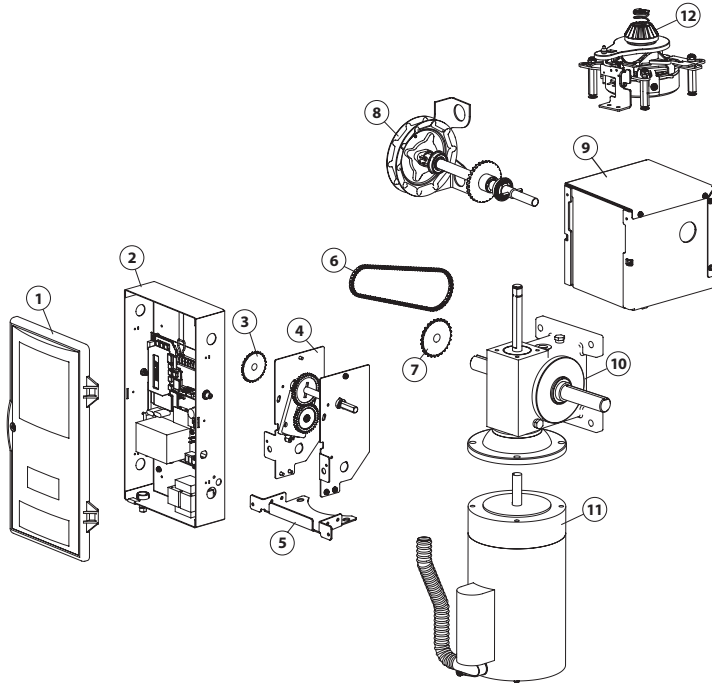


Figure 7

# Sidemount Trolley Operator Parts Breakdown

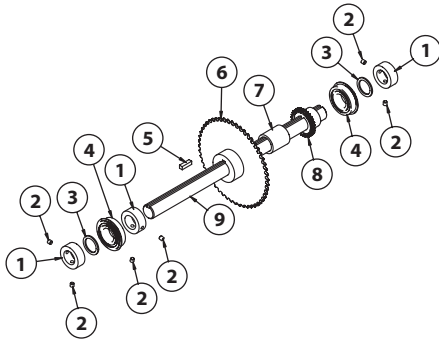
(SUPPLEMENT TO APPENDIX A OF THE ACCOMPANYING RHX® INSTALLATION MANUAL)



Item	Part Number	Description	Qty
	<b>111587.0001</b>	<b>OPER ASSY, RHXH, 3HP</b>	
1	110505.0001	COVER, ELECTRIC BOX, BLUE	1
2	110630.0001	ELECTRIC BOX	1
3	111536.0001	SPROCKET, #25, 1/4P, 28T	1
4	111602.0001	ENCLOSURE ASSY, LIMIT, RHXH	1
5	111525.0001	ENCLOSURE, LIMIT, RHXH	1
6	086565.1032	CHAIN, RLR, #25 X 76P, LOOP	1
7	111537.0001	SPROCKET, #25, 1/4P, 38T	1
8	111601.0001	SHAFT ASSY, HOIST, RHXH	1
9	111527.0001	ENCLOSURE ASSY, BRAKE, RHXH	1
10	111503.0001	GEAR REDUCER, 40:1, RHXH	1
	111503.0002	GEAR REDUCER, 20:1, RHXH	1
11	111502.0001	MOTOR, 1/2 HP, 1 PH, OPEN DRIP, RHX	1
	111502.0002	MOTOR, 3/4 HP, 1 PH, OPEN DRIP, RHX	1
	111502.0003	MOTOR, 1 HP, 1 PH, OPEN DRIP, RHX	1
	111502.0004	MOTOR, 1/2 HP, 3 PH, OPEN DRIP, RHX	1
	111502.0005	MOTOR, 3/4 HP, 3 PH, OPEN DRIP, RHX	1
	111502.0006	MOTOR, 1 HP, 3 PH, OPEN DRIP, RHX	1
	111502.0007	MOTOR, 1/2 HP, 575V, OPEN DRIP, RHX	1
	111502.0008	MOTOR, 3/4 HP, 575V, OPEN DRIP, RHX	1
	111502.0009	MOTOR, 1 HP, 575V, OPEN DRIP, RHX	1
12	111598.0001	BRAKE ASSY, RHXH	1

## Sidemount Trolley Output Shaft Parts Breakdown

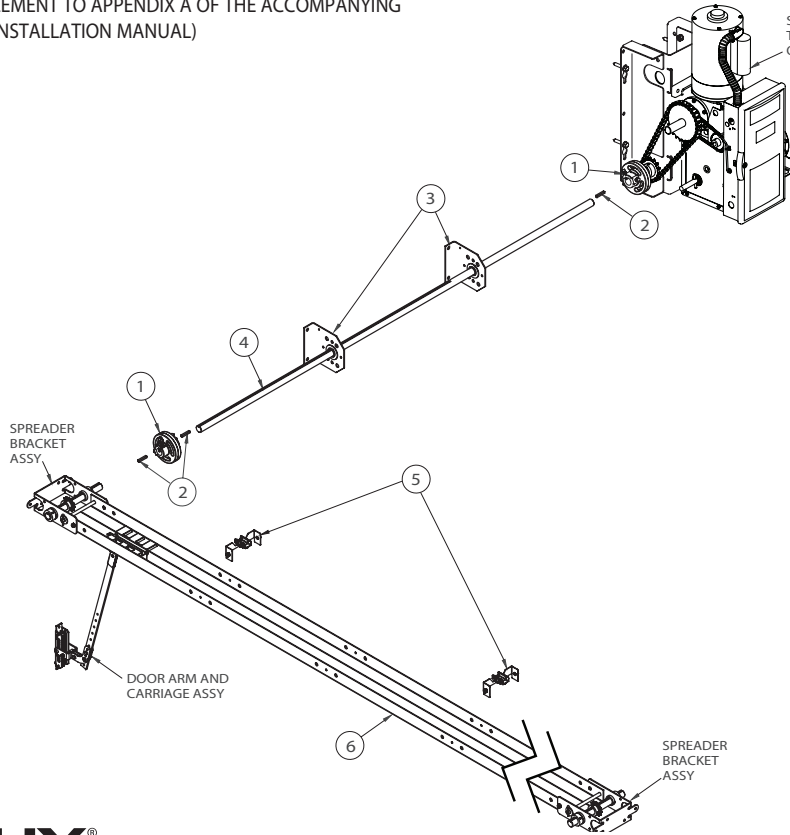
(SUPPLEMENT TO APPENDIX A OF THE ACCOMPANYING RHX® INSTALLATION MANUAL)



Item	Part Number	Description	Qty
A	111426.0001	SERVICE KIT, OUTPUT SHAFT, SIDEMOUNT TROLLEY	
1	604297.4100	COLLAR, SET, 1" ID X 1-5/8" OD	3
2	080300.1604	SCREW, SET, 5/16" X 1/4" X 1/4"	6
3	110819.0002ZZ	WASHER, PLAIN, 1.026" ID	2
4	110694.0001	BEARING, 1.000" ID	2
5	080340.0074	KEY, STD, SQ, 1/4" X 7/8"	1
6	110663.0005	SPROCKET, 52T, #35 CHAIN, 3/8"	1
7	111044.0001	SPACER, OUTPUT SHAFT	1
8	111185.0001	GEAR, LIMIT, 30T, SIDEMOUNT	1
9	110644.0001	SHAFT, OUTPUT, 1" DIA.	1

# Sidemount Track Parts Breakdown

(SUPPLEMENT TO APPENDIX A OF THE ACCOMPANYING  
RHX® INSTALLATION MANUAL)



Item	Part Number	Description	Qty
1	607586.0001	COUPLING ASSY	2
2	080340.0016	KEY, 1/4" X 1-1/2	4
3	051098.0003	BRACKET ASSY	2
4	608515.XXXX	1 SHAFT	1
		SHAFT LENGTHS ARE CUSTOM FIT TO YOUR DOOR'S SPECIFICATIONS.	
5	111390.0001	CHAIN GUIDE	2 OR 3*
6		RAIL	
	110732.1125	8" DOOR	1
	110732.1149	10" DOOR	1
	110732.1173	12" DOOR	1
	110732.1197	14" DOOR	1
	110732.1221	16" D	1
	110732.1245	18" DOOR	1
	110732.1269	20" DOOR	1
	110732.1317	24" DOOR	1

RAILS ARE ORDERED SEPARATELY BY LENGTH, AND ARE ORDERED DIRECTLY FROM THE DOOR PLANTS. WHEN ORDERING, MAKE SURE YOU MEASURE YOUR RAIL FIRST. THE LAST THREE NUMBERS OF THE PART NUMBER ARE THE LENGTH OF THE RAIL IN INCHES.

\*DEPENDS ON RAIL LENGTH.

DRIVE CHAIN — SEE PAGE.



# WARRANTY



**The Genuine. The Original.**



**RHX<sup>®</sup>**

**Commercial Operator Limited Warranty**

The authorized distributor of Overhead Door Corporation products, whose name appears below ("Seller") warrants to the original purchaser of the model RHX<sup>®</sup> Trolley or RHX<sup>®</sup> Hoist commercial door operator ("Product"), subject to all of the terms and conditions hereof, that the Product and all components thereof will be free from defects in materials and workmanship under normal use for the following components thereof will be free from defects in materials and workmanship under normal use for the following period(s), measured from the date of installation:

- Two (2) years

Seller's obligation under this warranty is specifically limited to repairing or replacing, at its option, any part which is determined by Seller to be defective during the applicable warranty period. Any labor charges are excluded and will be the responsibility of the purchaser.

This warranty is made to the original purchaser of the Product only, and is not transferable or assignable. This warranty applies only to an operator which is installed in commercial or industrial building applications. This warranty does not apply to any unauthorized alteration or repair of the Product, or to any Product or component which has been damaged or deteriorated due to misuse, neglect, accident, failure to provide necessary maintenance, normal wear and tear, or acts of God or any other cause beyond the reasonable control of Seller.

**THIS WARRANTY IS EXCLUSIVE AND IN LIEU OF ANY OTHER WARRANTIES, EITHER EXPRESS OR IMPLIED, INCLUDING BUT NOT LIMITED TO ANY IMPLIED WARRANTY OF MERCHANTABILITY OR FITNESS FOR A PARTICULAR PURPOSE.**

**IN NO EVENT SHALL SELLER BE RESPONSIBLE FOR, OR LIABLE TO ANYONE FOR, SPECIAL, INDIRECT, COLLATERAL, PUNITIVE, INCIDENTAL OR CONSEQUENTIAL DAMAGES,** even if Seller has been advised of the possibility of such damages. Such excluded damages include, but are not limited to, loss of goodwill, loss of profits, loss of use, cost of any substitute product, interruption of business, or other similar indirect financial loss.

Claims under this warranty must be made promptly after discovery, within the applicable warranty period, and in writing to the Seller or to the authorized distributor or installer whose name and address appear below. The purchaser must allow Seller a reasonable opportunity to inspect any Product claimed to be defective prior to removal or any alteration of its condition. Proof of the purchase and/or installation date, and identification as the original purchaser, may be required.

ORIGINAL PURCHASER \_\_\_\_\_

INSTALLATION ADDRESS \_\_\_\_\_

SELLER: \_\_\_\_\_

SELLER'S ADDRESS: \_\_\_\_\_

FACTORY ORDER #: \_\_\_\_\_

DATE OF INSTALLATION: \_\_\_\_\_

SIGNATURE OF SELLER: \_\_\_\_\_



Overhead Door Corporation  
2501 S. State Hwy 121 Bus., Suite 200  
Lewisville, TX 75067  
1-800-929-3667(DOOR)  
[www.overheaddoor.com](http://www.overheaddoor.com)

---